

SK7456U3TO

Monochrome Line Scan Camera

7456 pixels, 4.7 μm x 4.7 μm , 40 MHz pixel frequency

USB 3.0

- Robust cable connections
- Hot-pluggable
- Perfect for movable setups

Instruction Manual

11.2015



Sample Configuration

- 1** CCD line scan camera
SK7456U3TO
mounted with
- 2** Mounting bracket SK5105
- 3** Clamping claws SK5102
- 4** Photo lens SK1.4/50-40
(integrated focus/aperture adjustment)



Read the manual carefully before the initial start-up. For the content table refer to page 3.
The producer reserves the right to change the herein described specifications in case of technical advance of the product.

How to Use this Instruction Manual



Please read the following sections of this Instruction Manual before unpacking, assembly or use of the Line Camera System:

- The safety warnings on this page
- Introduction to the system, page 4
- Assembly and initial setup, page 6

Keep this Instruction Manual in a safe place for future reference.

Safety Warnings



▶ Electricity Warning

Assembly and initial operation of the line scan camera must be carried out under dry conditions.

Do not operate the camera if you notice any condensation or moisture in order to avoid danger of a short circuit or static discharge!

For typical use in a scanning application, please consider the following warnings:



▶ Mechanical Warning

Ensure that the scanner axis is free to move and that no obstacles are in the way – **especially fingers!**

Do not place any body parts in the way of moving parts!



▶ Risk of High Power Lighting

According to the application laser or high power LED light sources might be used. These can affect your eyesight temporarily or even cause permanent damage to the eyes or skin.

Do not look directly into the light beam!

Contents

How to Use this Instruction Manual.....	2
Safety Warnings	2
Contents	3
1 Introduction	4
1.1 Intended Purpose and Overview.....	4
1.2 System Setup at a Glance	4
1.3 Computer System Requirements.....	5
1.4 SK7456U3TO Line Scan Camera - Specifications.....	5
2 Installation and Setup	6
2.1 Mechanical Installation: Mounting Options and Dimensions.....	6
2.2 Electrical Installation: Connections and I/O Signals	7
2.3 USB3 Connections and SkLineScan Software Installation.....	8
SkLineScan Installation and Automatic Camera Driver Installation	
SkLineScan Start-up	
Camera Setup	
Initial Function Test	
3 Camera Control and Performing a Scan.....	10
3.1 Software: SkLineScan.....	10
Function Overview: SkLineScan Toolbar	
Basic Visualization of the Sensor Output	
3.2 Adjustments for Optimum Scan Results.....	12
Lens Focussing	
Sensor Alignment	
Gain/Offset Control Dialog	
Shading Correction	
Integration Time	
Synchronization of the Imaging Procedure and the Object Scan Velocity	
Synchronization Modes	
4 Advanced SkLineScan Software Functions	18
4.1 Camera Control by Commands	18
Set Commands	
Request Commands	
4.2 Advanced Synchronization Control.....	20
Advanced Trigger Functions and Sync Control Register Settings	
Example Timing Diagrams of Advanced Synchronization Control	
5 Sensor Information.....	22
Features	
Circuit Diagram and Pin Names	
Optical/Electrical Characteristics	
Glossary	26
CE-Conformity.....	27
Warranty.....	27
Accessories and Spare Parts.....	28

1 Introduction

1.1 Intended Purpose and Overview

The SK line scan camera series is designed for a wide range of vision and inspection applications in industrial and scientific environments. The SK7456U3TO is highly portable and the robustly attached dedicated connections enable external synchronization of the camera and the output of data to the USB 3.0 port of the computer.

The USB 3.0 connection supplies power to the camera and the camera is hot-pluggable, providing the greatest degree of flexibility and mobility. The computer does not require a grabber board, allowing a laptop to be used when space or weight restrictions are also at a premium.

Once the camera driver and the SkLineScan® program have been loaded from the SK91USB3-WIN CD then the camera can be parameterized. The parameters, such as integration time, synchronization mode or shading correction, are permanently stored in the camera even after a power-down or disconnection from the PC.

The oscilloscope display in the SkLineScan® program can be used to adjust the focus and aperture settings, for evaluating field-flattening of the lens and for orientation of the illumination and the sensor, see **3.1 Software: SkLineScan, p. 10.**

1.2 System Setup at a Glance

- red: SK7456U3TO scope of delivery
- blue: accessories for minimum system configuration
- black: optional accessories

For accessory order details see *Accessories and Spare Parts, p. 28.*

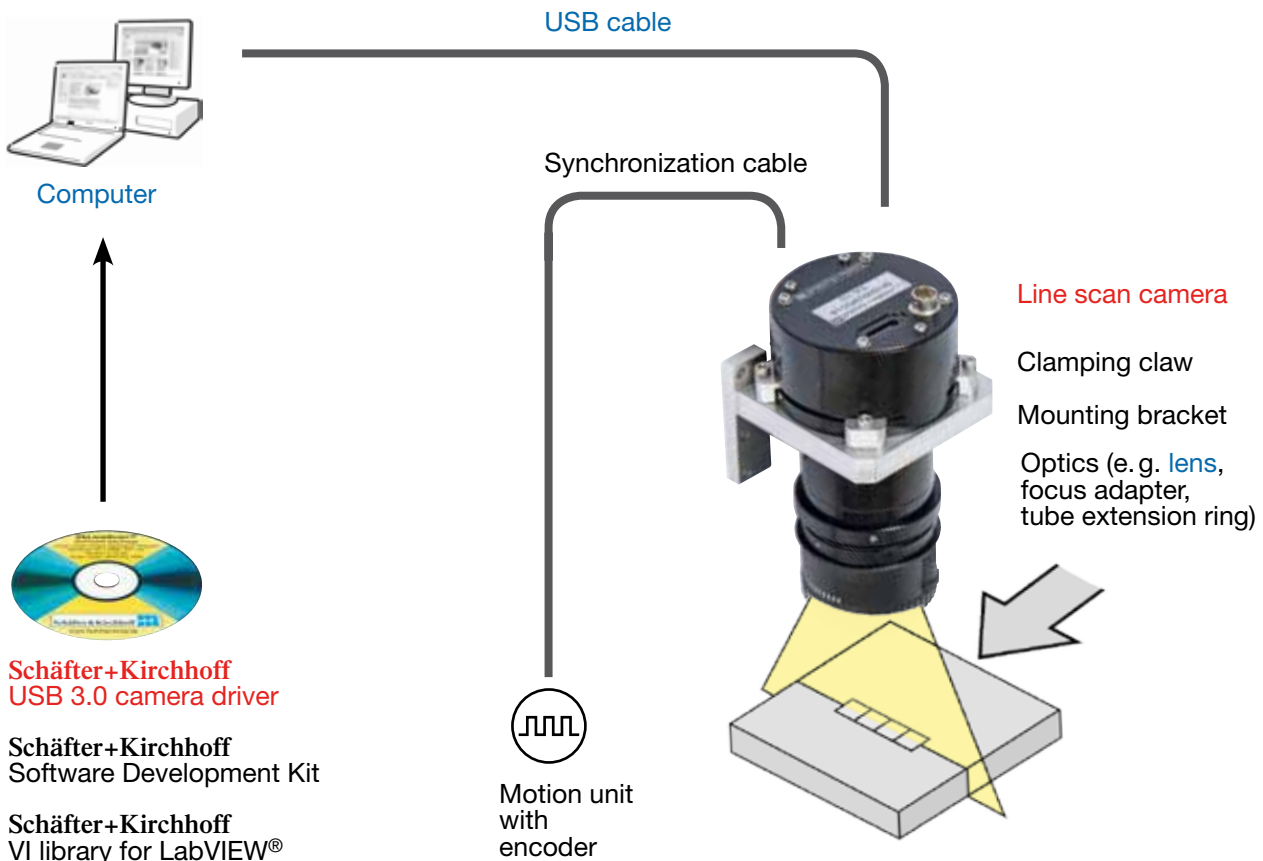

1.3 Computer System Requirements

- Intel Pentium Dual Core or AMD equivalent
- RAM min. 4 GB, depending on the size of acquired images
- USB 3.0 interface. With a USB 2.0 interface, there are limitations, see footer.
- High-performance video card, PCIe bus
- Operating System Windows 7 (64 or 32-bit)
- CD/DVD drive for software installation

1.4 SK7456U3TO Line Scan Camera - Specifications

Sensor category	CCD Monochrome Sensor
Sensor type	TCD1711DG
Pixel number	7456
Pixel size (width x height)	4.7 x 4.7 μm^2
Pixel spacing	4.7 μm
Active sensor length	35.04 mm
Anti-blooming	-
Integration control	-
Shading correction	x
Line synchronization modes	Line Sync, Line Start, Exposure Start
Frame synchronization	x
Pixel frequency	40 MHz
Maximum line frequency	5.2 kHz
Integration time	0.19 ... 20 ms
Dynamic range	1:1000 (rms)
Spectral range	400 ... 900 nm
Video signal	monochrome 8/12 Bit digital
Interface	USB 3.0
Voltage	USB (400 mA)
Power consumption	2.0 W
Casing	\varnothing 65 mm x 54 mm (Case type AT2)
Objective mount	M40x0.75
Flange focal length	19.5 mm
Weight	0.2 kg
Operating temperature	+5 ... +45°C

Note:

This camera is USB 2.0 downward compatible with following limitations:

When connected to a USB 2.0 interface, the pixel data transfer rate is limited to 20 MByte/s (i.e. 20 MHz pixel frequency at 8 bit video signal) and the line frequency is limited accordingly.

2 Installation and Setup

2.1 Mechanical Installation: Mounting Options and Dimensions

Mounting Options

- The best fixing point of the camera is the seat for the mounting bracket SK5105, which is available as an accessory.
- Four threaded holes M3x6.5mm provide further options for customized brackets.
- The length and weight of the optics might be beyond the capability of the standard mounting bracket SK5105. For this purpose, a second mounting bracket type SK5105-2 to hold the tube extension ring(s) is more appropriate.

Optics Handling

- If the camera and the optics are ordered as a kit, the components are pre-assembled and shipped as one unit. Keep the protective cap on the lens until the mechanical installation is finished.
- If you must handle with an open sensor or lens surface, make sure the environment is as dust-free as possible.
- Blow off loose particles using clean compressed air.
- The sensor and lens surfaces can be cleaned with a soft tissue moistened with water or a water-based glass cleaner.

Casing type AT2

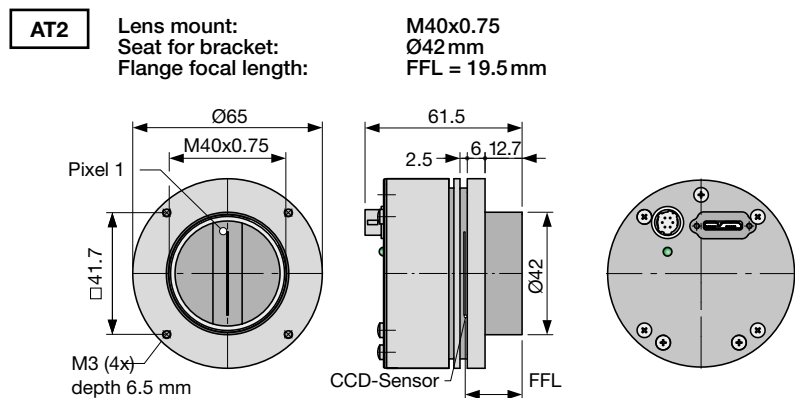

Mounting bracket SK5105

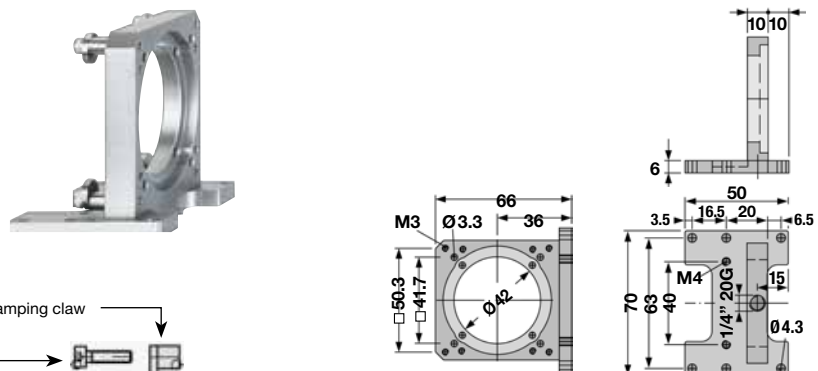

Clamping set SK5102

Set of 4 pcs. clamping claws
incl. screws

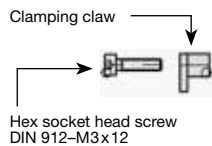

Mounting system SK5105-2

for cameras with a tube
extension > 52 mm

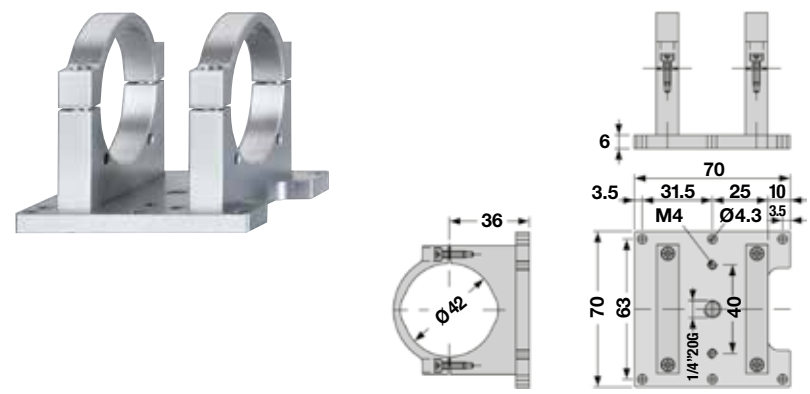

2.2 Electrical Installation: Connections and I/O Signals

- The USB 3.0 interface provides data transfer, camera control and power supply capabilities to the SK7456U3TO line scan camera. If you want to operate the camera in Free Run (SK Mode 0) trigger mode the USB 3.0 cable is the only connection you have to make.
- For any kind of synchronized operation, the external trigger signal(s) have to be wired to socket **2**. A frame synchronization signal and two separate line synchronization signals can be handled. The various trigger modes are described in section *Synchronization of the Imaging Procedure and the Object Scan Velocity*, p. 16

All Schäfter + Kirchhoff USB 3.0 line scan cameras can be operated with a USB 2.0 interface. Note that there might be limitations in terms of the maximum data transfer rate and the power supply. The details for your camera can be found in section 1.4 *Line Scan Camera - Specifications*, p. 5.

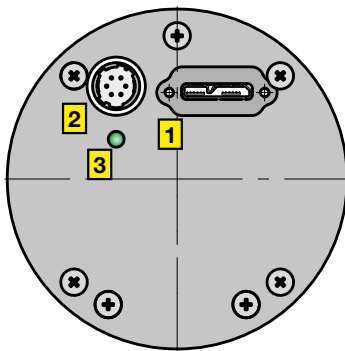
**1**

Data and power

USB 3.0 socket type μ B with threaded holes for locking screws
Power: 2.0 W

2

Synchronization

Socket: Hirose series 10A, male 6-pin

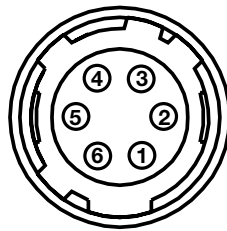



Pin	Signal	Pin	Signal
1	Line Sync B	4	NC
2	NC	5	Line Sync A
3	Frame Sync	6	GND

Line Sync A/B and Frame Sync: TTL levels

3

Status indicator

-  off no power, check the USB link for a fault.
-  red power on
-  green power on, firmware is loaded, camera is ready

USB 3.0 cable SK9020.x

For connecting socket **1** with the PC or USB hub.

Cable length:

- 3.0 m SK9020.3 (standard)
- 5.0 m SK9020.5



External synchronization cable SK9026.x

Use this cable to feed external synchronization signals into socket **2**.

Connectors:

- Hirose plug HR10A, female 6 pin (camera side)
- Phoenix 6 pin connector incl. terminal block

Cable length:

- 3.0 m SK9026.3
- 5.0 m SK9026.5



2.3 USB3 Connections and SkLineScan Software Installation

This section is a quick reference for installing the **SkLineScan** adjustment and configuration software and to set up the USB3 camera driver. SkLineScan and the SkLineScan manual is provided for download on the Schäfter+Kirchhoff website under <http://www.sukhamburg.com/support.html>. It is also part of the fee-based software development kit **SK91USB3-WIN**.

- Step 1:** Install **SkLineScan**. The setup program will automatically install the Schaefter + Kirchhoff USB3 Line Scan Camera Driver.
- Step 2:** Plug in the USB3 connection cable to the camera. if appropriate switch on the external power supply.
- Step 3:** Start the **SkLineScan** program.

SkLineScan Installation and Automatic Camera Driver Installation

Prior to the installation, power on the PC (not the camera) and unpack the downloaded zip-file to a temporary folder. Alternatively, if your installation medium is a CD, insert the disk to the drive.

The autostart function may launch the setup program automatically from CD. Otherwise, look for one of these installation files:

- SkLineScan-USB3-Win_x64.msi
- SkLineScan-USB3-Win_x86.msi
- SK91USB3-Win_x64.msi
- SK91USB3-Win_x86.msi

Then start the applicable installation file manually. This will set up the Schäfter + Kirchhoff **SkLineScan** camera control and adjustment tool as well as the USB3 Line Scan Camera Driver.

SkLineScan Start-up

- Start SkLineScan.
- A start-up dialog box pops up and displays the connected camera(s) that have been automatically detected. It also indicates the active USB standard. The optimum performance is provided by USB3.0.
- The camera LED changes from red to green color light.

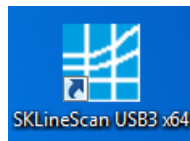

Desktop Icon

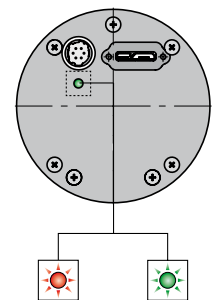

Camera Setup

Use the Setup dialog for

- activating/deactivating a connected USB3 camera (activated device is ticked)
- changing the pixel frequency
- setting the bit depth of the video signal to 8 or 12-bit.

In USB2.0 mode the lower pixel frequency and 8-bit video signal is recommended

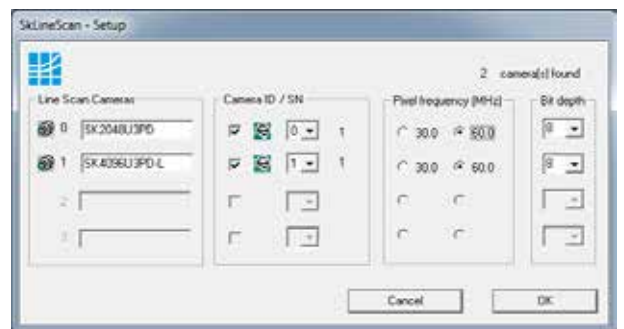

SkLineScan Setup dialog

Initial Function Test

- Quit the SkLineScan startup dialog box.
- Select "OK" in the SkLineScan start-up dialog.

The Signal Window showing the current brightness versus the pixel number indicates the correct installation.

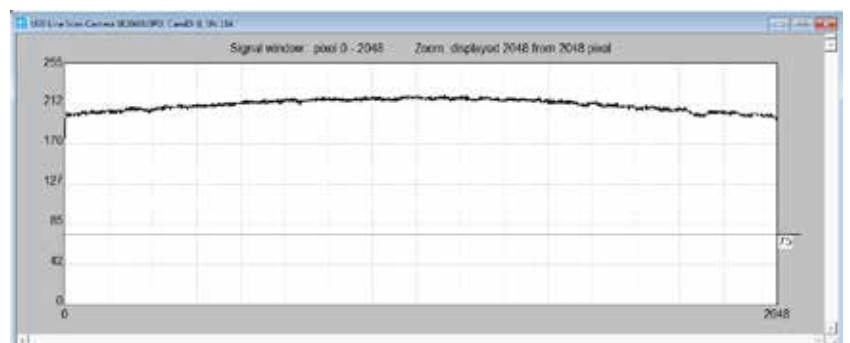

3 Camera Control and Performing a Scan

3.1 Software: SkLineScan

This section is a brief introduction for how to work with the SkLineScan adjustment and configuration software. A more detailed description is provided in the separate SkLineScan manual. The document (pdf) is included in the SkLineScan installation package. Further it is available for download on the Schäfter + Kirchhoff website under <http://www.sukhamburg.com/support.html>.

For an in-depth guide on how to carry out imaging and how to work with the obtained data with the Schäfter + Kirchhoff software package, see the *SkLineScan software manual*.

The most common functions of the line scan camera can be controlled by menu items and dialog boxes.

Commands for comprehensive camera functionality can be entered in the "Camera Gain / Offset Control" dialog.

Click on the desktop icon to start the **SkLineScan** program.

The SkLineScan program recognizes the connected line scan cameras automatically. The identified cameras are shown in the start-up dialog **A**, and the index order corresponds with the individual MAC addresses of the cameras.

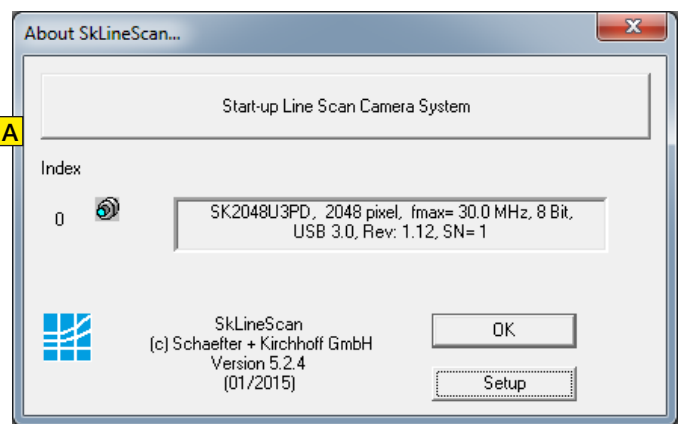







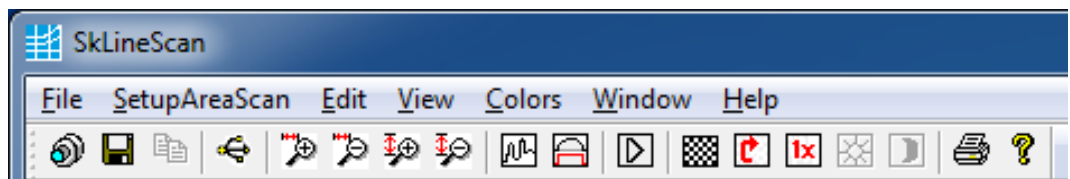

SkLineScan: Start-up dialog

If the SK7456U3TO camera is identified correctly confirm with "OK". The "Signal window" graphically showing the intensity signals of the sensor pixels (oscilloscope display) will open. It is responsive in real-time, and the zoom function can be used to highlight an area of interest. The oscilloscope display is ideally suited for parameterizing the camera, for evaluating object illumination, for focussing the image or for aligning the line scan camera correctly.

Function Overview: SkLineScan Toolbar



SkLineScan: Toolbar

-  New line scan. All open "Signal window" windows will be closed. [F2]
-  "Camera Control" dialog for parameter settings: integration time, line frequency, synchronization mode, thresholding
-  Zooming in and out
-  New line scan. "Area Scan" windows will be closed, "Signal window" windows will remain open. [F2]
-  Threshold mode in new binary signal window.
-  "Shading Correction" dialog to adjust the white balance [Alt + s]
-  "Gain/Offset Control" dialog, also commands input [Shif+F4]
-  New area scan

Basic Visualization of the Sensor Output

Signal Window / Oscilloscope Display

The signal window plots the digitalized brightness profile as signal intensity (y-axis) versus the sensor length (x-axis) at a high refresh rate. The scaling of the y-axis depends on the resolution of the A/D converter: The scale range is from 0 to 255 for 8-bits and from 0 to 4095 for 12-bits. The scaling of the x-axis corresponds with the number of pixels in the line sensor.

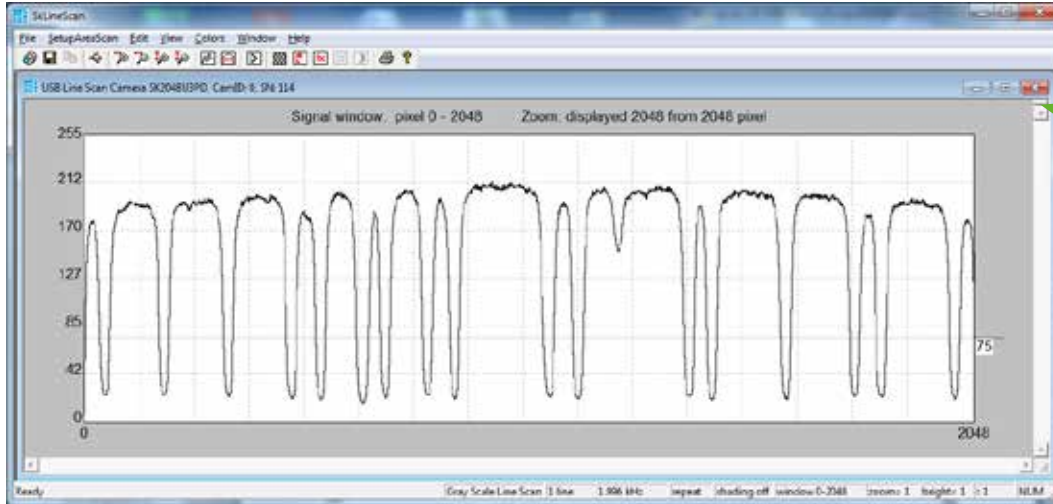

Line scan in Signal Window: brightness vs. pixel number

Zoom Function

For high numbers of sensor pixels, the limited number of display pixels might be out of range, in which case the zoom function can be used to visualize the brightness profile in detail. Magnification of one or several sections of the signal allows individual pixels to be resolved for a detailed evaluation of the line scan signal.

Window Split Function B

The signal window can be split horizontally into two sections. Use the split handle at the top of the vertical scroll bar and afterwards arrange the frames with the zoom buttons in the toolbar.

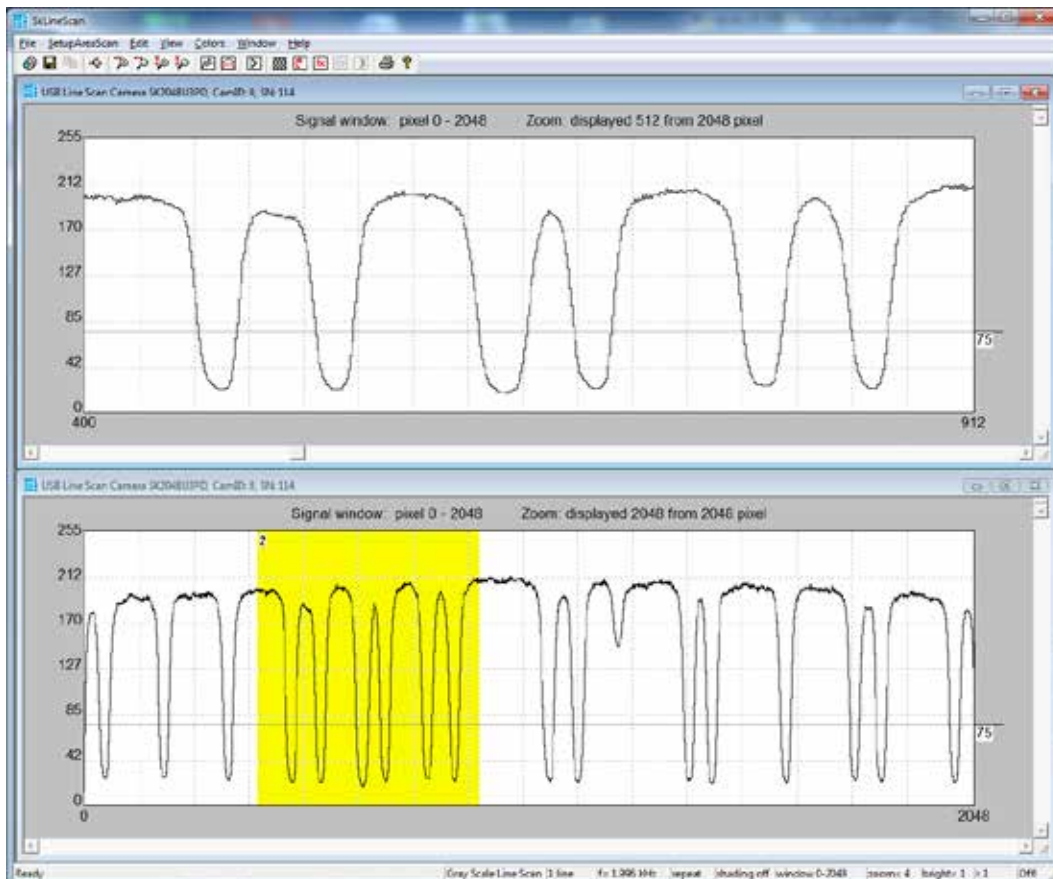

Line scan in Signal Split signal window. The upper frame shows a magnified section of the lower frame.

Line Scan Camera SK7456U3TO Manual (11.2015) • shared_CameraControl1_SkLineScan_ML_inde (11.2015)

3.2 Adjustments for Optimum Scan Results

Prior to a scan, the following adjustments and parameter settings should be considered for optimum scan signals:

- Lens focussing
- Sensor alignment
- Gain/Offset
- Shading correction
- Integration time
- Synchronization of the sensor exposure and the object surface velocity, trigger mode options

Start with the signal window / oscilloscope display. Any changes in the optical system or camera parameters are displayed in real-time when using an open dialog box.

Lens Focussing

To focus a line scan camera, the variations in edge steepness at dark/bright transitions and the modulation of the line scan signal are decisive.

- Adjust the focus using a fully opened aperture to restrict the depth of field and to amplify the effects of focus adjustments.
- A fully open aperture might cause a too high a signal amplitude, in which case the integration time should be shortened, as described in *Integration Time, p. 15*.

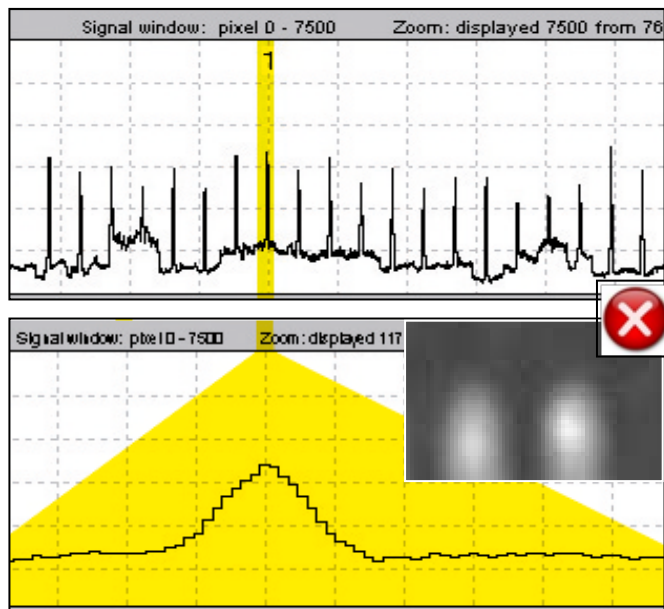

Out of focus: edges are indistinct, signal peaks blurred with low density modulation

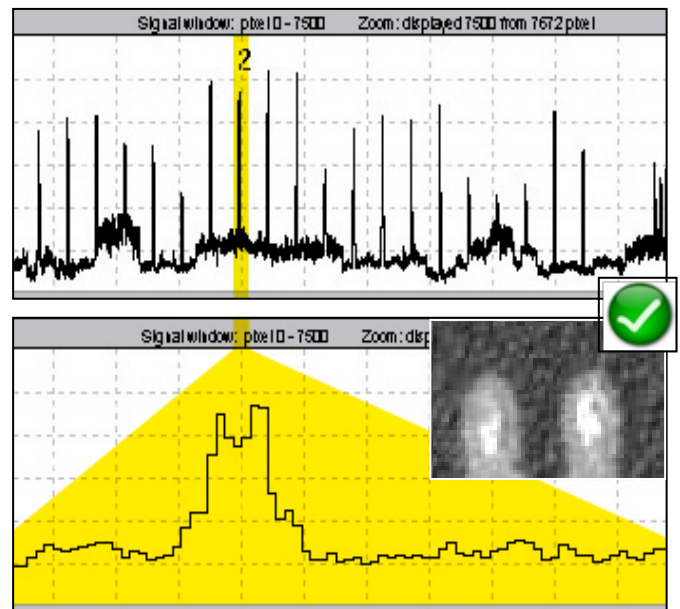

Optimum focus: dark-bright transitions are sharp edged, highly modulated signal peaks with high frequency density variations

Sensor Alignment

If you are operating with a linear illumination source, check the alignment of the illumination source and the sensor prior to a shading correction, as rotating the line sensor results in asymmetric vignetting.

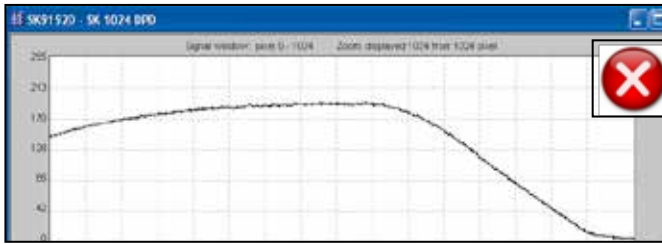

Sensor and optics rotated in apposition

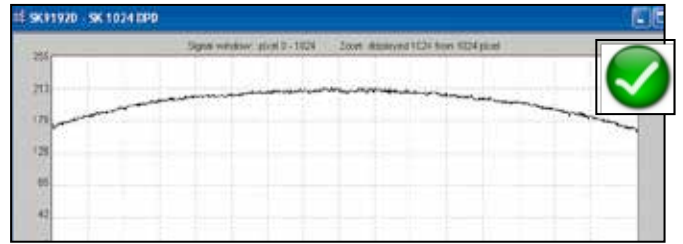

Sensor and optics aligned

Gain/Offset Control Dialog

Cameras are shipped prealigned with gain/offset factory settings. Open the "Gain/Offset Control" dialog [Shift+F4] to re-adjust or customize settings.

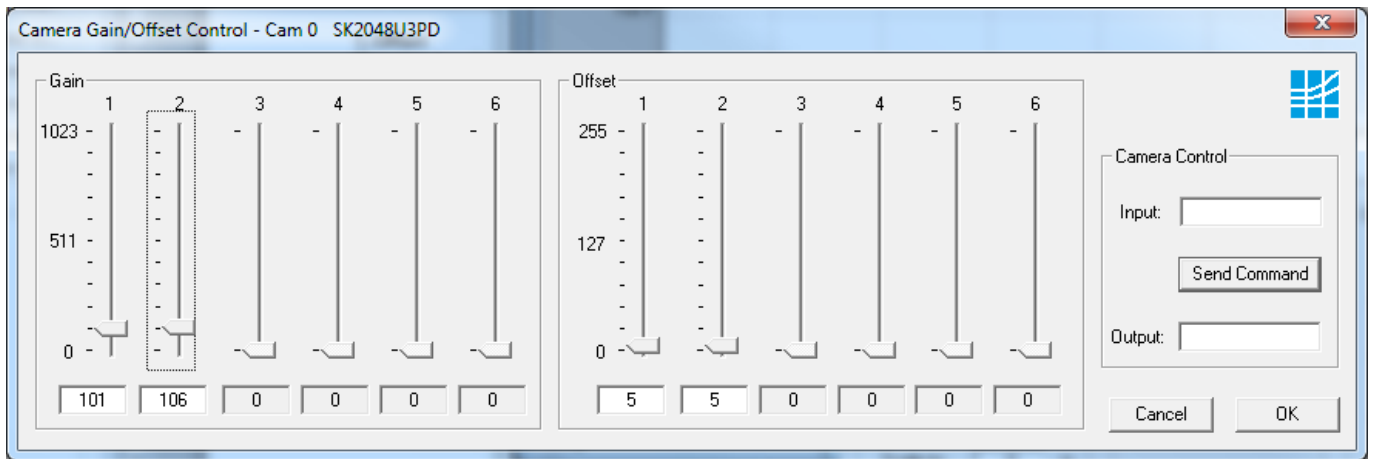

Gain/Offset Control dialog

The gain/offset dialog contains up to 6 sliders for altering gain and offset. The number of active sliders depends on the individual number of adjustable gain/offset channels of the camera.

The 'Camera Control' frame on the right is used for commands and advanced software functions. (→ 4.1 Camera Control by Commands, p. 20)

Adjustment principle

1. Offset

To adjust the zero baseline of the video signal, totally block the incident light and enter "00" (volts) for channel 1.

For a two- or multi-channel sensor minimize any differences between the channels by adjusting the other Offset sliders.

A slight signal noise should be visible in the zero baseline.

2. Gain

Illuminate the sensor with a slight overexposure in order to identify the maximum clipping. Use the Gain slider "1" to adjust the maximum output voltage.

For a two- or multi-channel sensor minimize any differences between the channels by adjusting the other Gain sliders.

For the full 8-bit resolution of the camera, the maximum output voltage is set to 255 and for 12-bit is set to 4095.

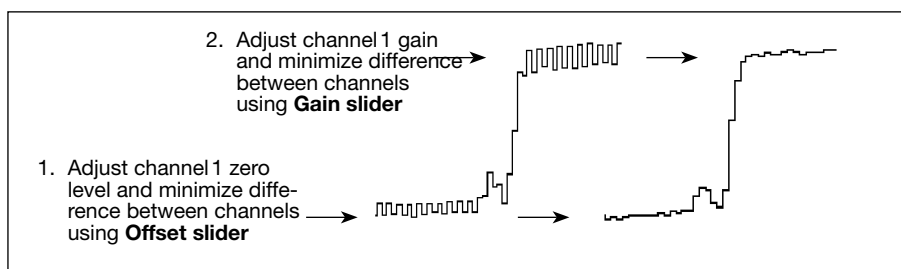

Offset and gain adjustment for more than one gain/offset channel

Shading Correction

Shading Correction compensates for non-uniform illumination, lens vignetting as well as any differences in pixel sensitivity. The signal from a white homogeneous background is obtained and used as a reference to correct each pixel of the sensor with an individual factor, scaled up to the intensity maximum (255 at 8-bit resolution and 4095 at 12-bit) to provide a flat signal. The reference signal is stored in the Shading Correction Memory (SCM) of the camera and subsequent scans are normalized using the scale factors from this white reference.

- Open the "Shading Correction" dialog (Alt+s).

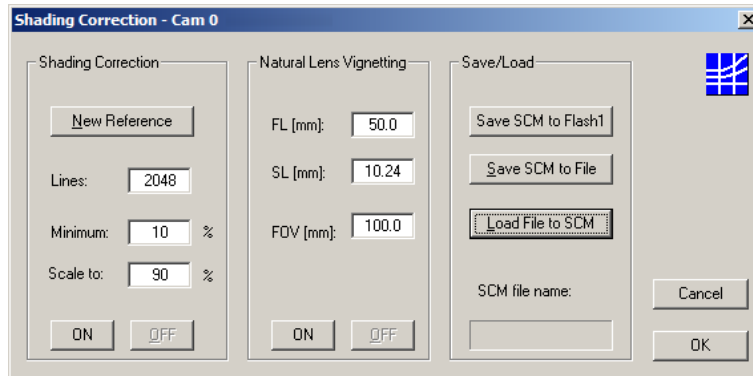

Shading Correction dialog

- Use a homogeneous white object to acquire the reference data, e.g. a white sheet of paper.
- Either take a 2-dimensional scan ("Area Scan Function" [F3]) or
- Click on button **New Reference**
- Click on **Save SCM to Flash** to save the SCM reference signal in the flash memory of the camera

use a single line signal that was averaged over a number of single line scans.

- To suppress any influence of the surface structure, move the imaged object during the image acquisition.
- Input the scale range:

Minimum in %: intensity values lower than "Minimum" will not be changed.

A typical appropriate value is 10% of the full intensity range, i.e. 26 (= 10% · 255) for an 8-bit intensity scale.

Maximum in %: target value for scaling

A typical appropriate value is 90% of the full intensity range. The result will be a homogeneous line at 230 (= 90% · 255) for an 8-bit intensity scale.

Once the reference signal is copied from the shading correction memory (SCM) to the camera flash memory it will persist even after a power down. On a re-start, this data will be restored from the flash memory back to the SCM. The current shading correction status - active or not active - is also retained on power down.

- ON** Activate Shading Correction with the reference signal which is stored in the SCM.
- OFF** Switch off Shading Correction. The Shading Correction is not retained in camera flash memory at the next start – even if the SCM data has already been saved into the flash memory previously.
- Load File to SCM** A stored reference signal will be loaded in the SCM of the camera. If the load process completes then the Shading Correction is active.



After shading correction, the line scan signal has a homogeneous intensity at 255 (8 bit, Maximum 100%)

Shading Correction Memories and API Functions

As an alternative to the user dialog, a new shading correction reference signal can also be created by using application programming interface (API) functions. The relationship between the storage locations and the related API functions are shown in the diagram below. The API functions are included in the SK91USB3-WIN software package. See the *SK91USB3-WIN manual* for details.

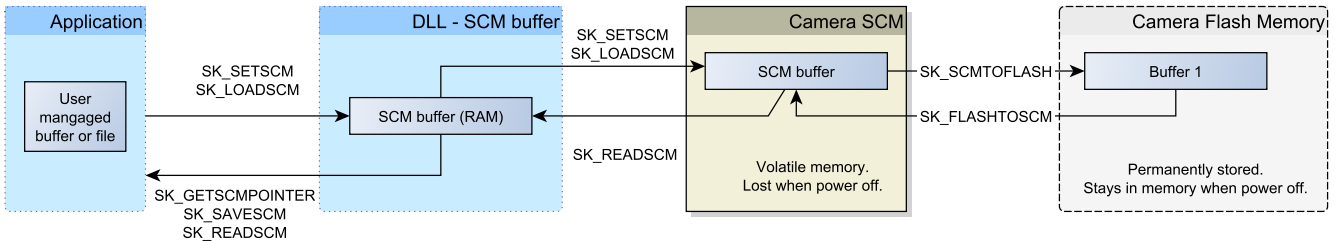

Structure of the shading correction memories and the related API functions for memory handling

Integration Time

The range of intensity distribution of the line scan signal is affected by the illumination intensity, the aperture setting and the camera integration time. Conversely, the aperture setting influences the depth of field as well as the overall quality of the image and the perceived illumination intensity.

The line scan signal is optimum when the signal from the brightest region of the object corresponds to 95% of the maximum gain. Full use of the digitalization depth (256 at 8-bit, 4096 at 12-bit) provides an optimum signal sensitivity and avoids over-exposure (and blooming).

- Open the "Camera Control" dialog. Menu *Edit -> Operation Parameters* or *[F4]*

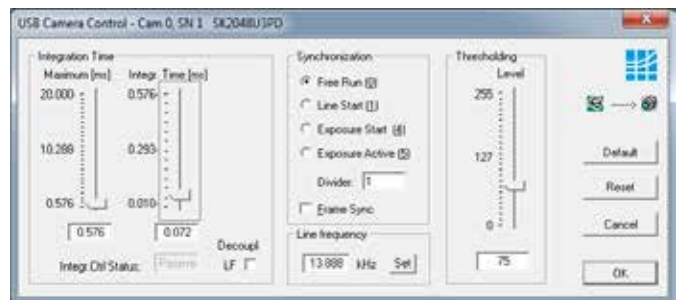

SkLineScan Camera Control dialog

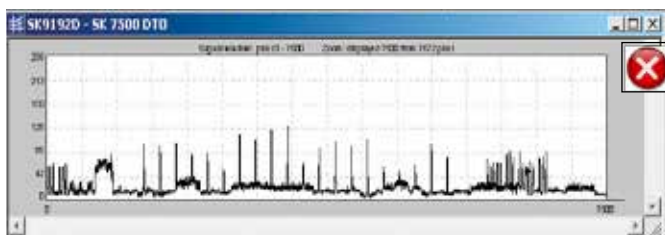

A camera signal exhibiting insufficient gain: the integration time is too short as only about 50% of the B/W gray scale is used.

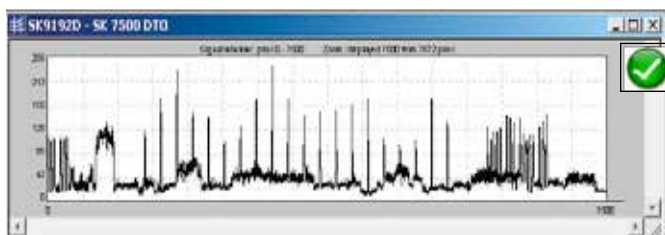

Optimized gain of the camera signal after increasing the integration time, by a factor of 4, to 95% of the available scale.

- The integration time can be set by two vertical sliders or two input fields in the section "Integration time" of this dialog. The left slider is for a coarser the right for finer adjustments.
- The current line frequency is displayed in the Line Frequency status field.
- The adjustment of the integration time in the range of Integration Control (shutter) with an integration time shorter than the minimum exposure period does not change the line frequency. This will be held at maximum.
- The 'Default' button sets the integration time to the minimum exposure period in respective of the maximum line frequency.
- 'Reset' restores the start values.
- 'Cancel' closes the dialog without changes.
- 'OK' stores the integration time values and closes the dialog.
- For synchronization settings see *Synchronization of the Imaging Procedure and the Object Scan Velocity*, p. 16.

Synchronization of the Imaging Procedure and the Object Scan Velocity

- A two-dimensional image is generated by moving either the object or the camera. The direction of the translation movement must be orthogonal to the sensor axis of the CCD line scan camera.
- To obtain a proportional image with the correct aspect ratio, a **line synchronous transport** with the laterally correct pixel assignment is required. The line frequency and the constant object velocity have to be adapted to each other.
- In cases of a variable object velocity or for particular high accuracy requirements then an **external synchronization** is necessary. The various **trigger modes** are described below.

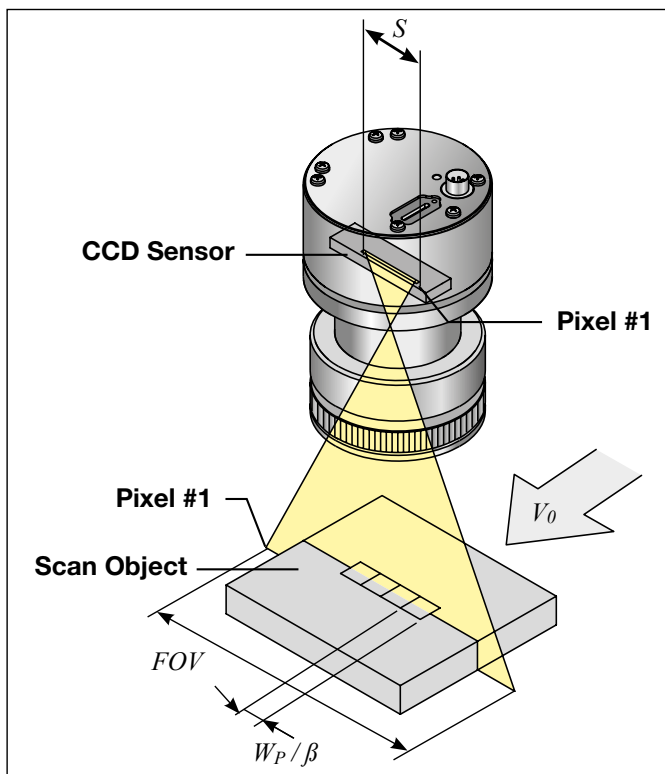

The optimum object scan velocity is calculated from:

$$V_o = \frac{W_p \cdot f_L}{\beta}$$

If the velocity of the object carrier is not adjustable then the line frequency of the camera must be adjusted to provide an image with the correct aspect ratio, where:

$$f_L = \frac{V_o \cdot \beta}{W_p}$$

- V_o = object scan velocity
- W_p = pixel width
- f_L = line frequency
- S = sensor length
- FOV = field of view
- β = magnification
- = S / FOV

Example 1:

Calculating the object scan velocity for a given field of view and line frequency:

- Pixel width = 4.7 μ m
- Line frequency = 5.2 kHz
- S = 35.04 mm
- FOV = 60 mm

$$V_o = \frac{4.7 \mu\text{m} \cdot 5.2 \text{ kHz}}{(35.04 \text{ mm} / 60 \text{ mm})} = 42 \text{ mm/s}$$

Example 2:

Calculating the line frequency for a given field of view and object scan velocity:

- Pixel width = 4.7 μ m
- Object scan velocity = 40 mm/s
- S = 35.04 mm
- FOV = 60 mm

$$f_L = \frac{40 \text{ mm/s} \cdot (35.04 \text{ mm} / 60 \text{ mm})}{4.7 \mu\text{m}} = 5 \text{ kHz}$$

Synchronization Modes

The synchronization mode determines the timing of the line scan. Synchronization can be either performed internally or triggered by an external source, e.g. an encoder signal.

The line scan camera can be externally triggered in two different ways:

1. Line-triggered synchronization:

Each single line scan is triggered by the falling edge of a TTL signal supplied to LINE SYNC A input.

The SK7456U3TO line scan camera facilitates advanced synchronization control by a second trigger input LINE SYNC B. For a detailed description see **4.2 Advanced Synchronization Control, p. 20**

2. Frame-triggered synchronization:

A set of lines resulting in a 2-dimensional frame or image is triggered by the falling edge of a TTL signal on FRAME SYNC input.

Schäfter + Kirchhoff differentiates several trigger modes identified by a number, which can be selected in the control dialog as appropriate.

- Open the 'Camera Control' dialog [F4] to configure the synchronization. The trigger mode settings are available in the middle frame.
- Frame- and line-triggered synchronization can be combined. Tick the 'Frame Sync' box to activate the frame synchronization mode.
- The Trigger Control stage is followed by a Trigger Divider stage inside the camera. Enter the division ratio into the 'Divider' field.

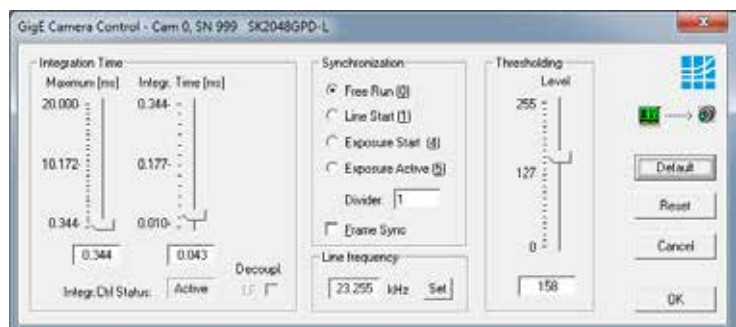

Camera Control dialog

Free Run / SK Mode 0

The acquisition of each line is internally synchronized (free-running) and the next scan is started automatically on completion of the previous line scan. The line frequency is determined by the programmed value.

LineStart / SK Mode 1

Initiated by the external trigger and the currently exposed line will be read out at the next internal line clock. The start and duration of exposure are controlled internally by the camera and are not affected by the trigger. The exposure time is programmable and the trigger does not affect the integration time. The line frequency is determined by the trigger clock frequency.

Restriction: The period of the trigger signal must be longer than the exposure time.

ExposureStart / SK Mode 4 (only available when camera supports integration control)

A new exposure is started exactly at the time of external triggering and the current exposure process will be interrupted. The exposure time is determined by the programmed value. The exposed line will be read out with the next external trigger. The trigger clock frequency determines the line frequency.

Restriction: The period of the trigger signal must be longer than the exposure time.

ExposureActive / SK extSOS (Mode 5)

The exposure time and the line frequency are controlled by the external trigger signal. This affects both the start of a new exposure (start-of-scan pulse, SOS) and the reading out of the previously exposed line.

FrameTrigger / SK FrameSync

The frame trigger synchronizes the acquisition of a 2D area scan. The individual line scans in this area scan can be synchronized in any of the available line trigger modes. The camera suppresses the data transfer until a falling edge of a TTL signal occurs at the FRAME SYNC input. The number of lines that defines the size of the frame must be programmed in advance.

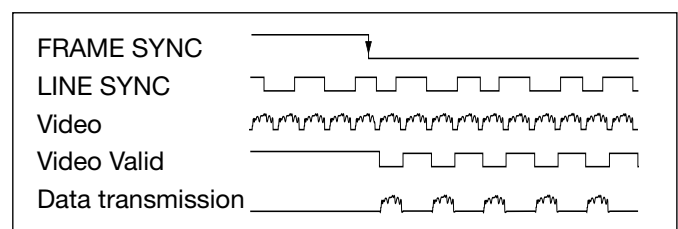

Combined frame and line synchronization

4 Advanced SkLineScan Software Functions

4.1 Camera Control by Commands

In addition to user dialog inputs, the SkLineScan software also provides the option to adjust any camera settings, such as gain, offset, trigger modes, by sending control commands directly.

Similarly, current parameters, as well as specific product information, can be read from the camera using the request commands. All set and request commands are listed in the tables below.

- The commands are entered in the 'Input' field in the 'Camera Control' section of the "Camera Gain/Offset Control" user dialog, [Shift+F4].
- In the 'Output' field either the acknowledgement of the set commands (0=OK, 1 = not OK) or the return values of the request commands are output.

The parameter settings are stored in the non-volatile flash memory of the camera and, thereby, are available for subsequent use and a rapid start-up, even after a complete shut down or loss of power.

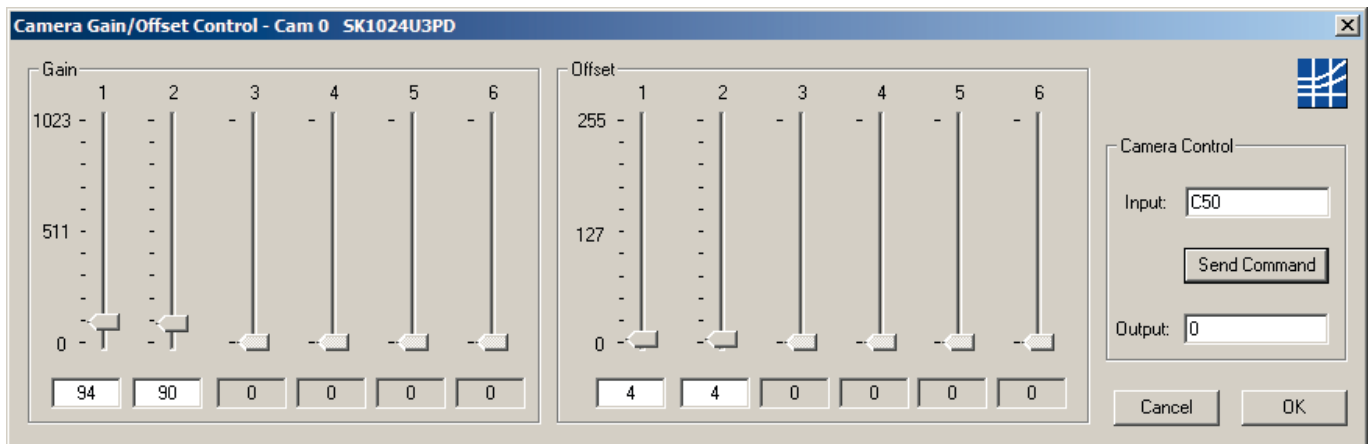

Gain/Offset Control dialog: Camera Control input and output in the right section

Set Commands

Set Operation	Description
Goooo<CR>	gain 1 setting (channel A) 0-24 dB
Boooo<CR>	gain 2 setting (channel B) 0-24 dB
Oppp<CR>	offset 1 setting (channel A)
Pppp<CR>	offset 2 setting (channel B)
F0<CR>	Output Format: threshold addr. (13 bit) no noise reduction
F1<CR>	Output Format: threshold addr. (13 bit) with noise reduction
F2<CR>	Output Format: threshold addr. (13 bit) no noise red., sub pixel (8 bit)
F3<CR>	Output Format: threshold addr. (13 bit) with noise red., sub pixel (8 bit)
F8<CR>	output format: 8 bit video data
F12<CR>	output format: 12 bit video data
C40<CR>	camera clock: 40 MHz data rate
T0<CR>	test pattern off / SCM off
T1<CR>	test pattern on (turns off with power off)
T2<CR>	shading correction on
T3<CR>	auto program Shading Correction / SCM on
T4<CR>	copy flash memory 1 to SCM
T5<CR>	save SCM to flash memory 1
T6<CR>	video out = SCM data
T7<CR>	copy Flash Memory 2 to LUT Memory
T8<CR>	save LUT Memory to Flash Memory 2
T9<CR>	Video out = LUT data
Lppp<CR>	set threshold level
M0<CR>	line trigger mode0: internal all lines
M1<CR>	line trigger mode1: extern trigger, next line
M2<CR>	line trigger mode0: internal all lines and set max line rate
M4<CR>	line trigger mode4: extern trigger and restart
M5<CR>	line trigger mode5: extern SOS, all Lines
Mx+8	frame trigger extern, start on falling edge
Mx+16	frame trigger extern, active low
Axxxx<CR>	SCM address (xxxxx = A0-A12239) or LUTM (xxxxx = A32768-A36863)
Dxxxx<CR>	SCM data (xxxx = 0-4095) and increment SCM address
Eyyyyy<CR>	frames / multiframe (yyyyy = 0-32767)
EFyyyyy<CR>	external frame trigger delay (yyyyy = 0-32767 lines)
Nyyyyy<CR>	lines / frame (yyyyy = 1-32767)
SLUT<CR>	enable LUT
RLUT<CR>	disable LUT
Wyyyyy<CR>	line clock frequency (yyyyy = 50-5200) (Hz)
WLyyyyy<CR>	Window Pixel length (yyyyy = 1-Line length)
WFyyyyy<CR>	Window First Pixel (yyyyy = 1-Line length)
Xyyyyy<CR>	exposure time (yyyyy = 190-20000) (µs)
Yyyyyy<CR>	extern sync divider (yyyyy = 1-32767)
Yppp<CR>	set sync control (ppp = 255)

Request Commands

Request	Return	Description
K<CR>	SK7456U3TO	returns SK type number
R<CR>	Rev1.22	returns Revision number
S<CR>	SNr00163	returns Serial number
I<CR>	SK7456U3TO Rev1.22 SNr00163	camera identification eadout
I1<CR>	VCC: yyyyy	returns VCC (1=10mV)
I2<CR>	VDD: yyyyy	returns VDD (1=10mV)
I3<CR>	moo: yyyyy	returns mode of operation
I4<CR>	CLo: yyyyy	returns camera clock low frequency (MHz)
I5<CR>	CHi: yyyyy	returns camera clock high frequency (MHz)
I6<CR>	Ga1: yyyyy	returns gain 1 (channel A)
I7<CR>	Ga2: yyyyy	returns gain 2 (channel B)
I8<CR>	Of1: yyyyy	returns offset 1 (channel A)
I9<CR>	Of2: yyyyy	returns offset 2 (channel B)
I19<CR>	Tab: yyyyy	returns video channels
I20<CR>	CLK: yyyyy	returns selected clock frequency (MHz)
I21<CR>	ODF: yyyyy	returns selected output data format
I22<CR>	TRM: yyyyy	returns selected trigger mode
I23<CR>	SCO: yyyyy	returns shading corr. on/off
I24<CR>	Exp: yyyyy	returns exposure time
I25<CR>	miX: yyyyy	returns min. exposure time (µs)
I26<CR>	LCK: yyyyy	returns line frequency (Hz)
I27<CR>	maZ: yyyyy	returns max. line frequency (Hz)
I28<CR>	TSc: yyyyy	returns Sync Divider
I29<CR>	SyC: yyyyy	returns Sync Control
I30<CR>	Lin: yyyyy	returns Lines/Frame
I31<CR>	DXT: yyyyy	returns DXT on/off
I32<CR>	Tmp: yyyyy	returns Video Board Temper.
I33<CR>	FSD: yyyyy	returns Frame Trigger Delay
I36<CR>	WPL: yyyyy	returns Window Pixel length
I37<CR>	WFP: yyyyy	returns Window First Pixel
I38<CR>	LUT: yyyyy	returns LUT on/off
I39<CR>	KST: yyyyy	returns Status

Acknowledgement for all set commands:
0 = OK, 1 = not OK

LUT: Lookup Table
SCM: Shading Correction Memory
SOS: Start of Scan

Range of values:
oooo = 0 ... 1023
ppp = 0 ... 255
xxxx = 4 digits integer value as ASCII
yyyyy = 5 digits integer value as ASCII

4.2 Advanced Synchronization Control

The basic synchronization function makes use of the trigger input LINE SYNC A. The trigger mode is determined by the settings in the "Camera Control" dialog, e.g. LineStart (1) or ExposureStart (4).

Advanced trigger functions are provided by combining LINE SYNC A with a second trigger input LINE SYNC B. The operation mode is controlled by the entries in the **Sync Control Register (SCR)**.

Use control commands to write to or to read from the Sync Control Register:

Yppp<CR> set sync control

with ppp = 0...255 (decimal)

Return value: 0 = OK; 1 = not OK

I29<CR> return sync control

Return value: SyC:yyyyy (5-digits integer value as ASCII)

Example:

Y232

ppp = 232(dec) = 11101000(bin)

new SCR value: 11101000 → **E**

Advanced Trigger Functions and Sync Control Register Settings

- Basic synchronization function, 'Camera Control' dialog settings are valid → **A**
- Detection of direction → **B, C, D, E**
- Trigger pulses are valid only in one direction, trigger pulses in the other direction are ignored → **B**
- Trigger on 4 edges → **D, E**
- Suppression of machine-encoded jitter, programmable hysteresis for trigger control → **E**

Sync Control Register (SCR)	SyC7	SyC6	SyC5	SyC4	SyC3	SyC2	SyC1	SyC0
default	x	x	x	x	x	x	0	0
pixel #1 data = external trigger input states	x	x	x	x	x	x	0	1
pixel #1 data = Linecounter (8 bit)	x	x	x	x	x	x	1	0
pixel #1, #2 data = ext. trigger states (3 bit) + line counter (13 bit)	x	x	x	x	x	x	1	1
ExSOS and Sync at LINE SYNC A (Mode5)	x	x	x	x	x	0	x	x
ExSOS at LINE SYNC B, Sync at LINE SYNC A (Mode5)	x	x	x	x	x	1	x	x
Jitter Hysteresis off	x	x	x	0	0	x	x	x
Jitter Hysteresis 4	x	x	x	0	1	x	x	x
Jitter Hysteresis 16	x	x	x	1	0	x	x	x
Jitter Hysteresis 64	x	x	x	1	1	x	x	x
Sync 1x Enable	x	x	0	x	x	x	x	x
Sync 4x Enable	x	x	1	x	x	x	x	x
Sync up Enable / down disable	x	0	x	x	x	x	x	x
Sync up/down Enable	x	1	x	x	x	x	x	x
Sync Control Disable	0	x	x	x	x	x	x	x
Sync Control Enable	1	x	x	x	x	x	x	x
	128	64	32	16	8	4	2	1

For diagnostic purposes, the present state of external trigger inputs (LINE SYNC A, LINE SYNC B, FRAME SYNC) or the internal line counter can be output instead of pixel #1 and/or pixel #2 data.

SCR	Pixel #1 Data (lowByte)	Pixel #2 Data (lowByte)
xxxxxx00	intensity	intensity
xxxxxx01	D7 = FRAME SYNC D6 = LINE SYNC A D5 = LINE SYNC B D4 ... D0 = 0	intensity
xxxxxx10	internal line counter (8 bit)	intensity
xxxxxx11	D7 = FRAME SYNC D6 = LINE SYNC A D5 = LINE SYNC B D4 ... D0 = line counter (bit 12 ... 8)	internal line counter (bit 7 ... 0)

Example Timing Diagrams of Advanced Synchronization Control

Annotations:

- SyncA = LINE SYNC A (external line synchronization input, I/O connector)
- SyncB = LINE SYNC B (external line synchronization input, I/O connector)
- Count = internal counter
- Trigger = Generated trigger pulses from the Trigger Control stage. The signal goes to the Trigger Divider stage inside the camera. For setting the divider use the Vyyyyy<CR> command or the 'Divider' input field in the **4.1 Camera Control by Commands, p. 20**.

- 1) direction changed
- 2) glitch

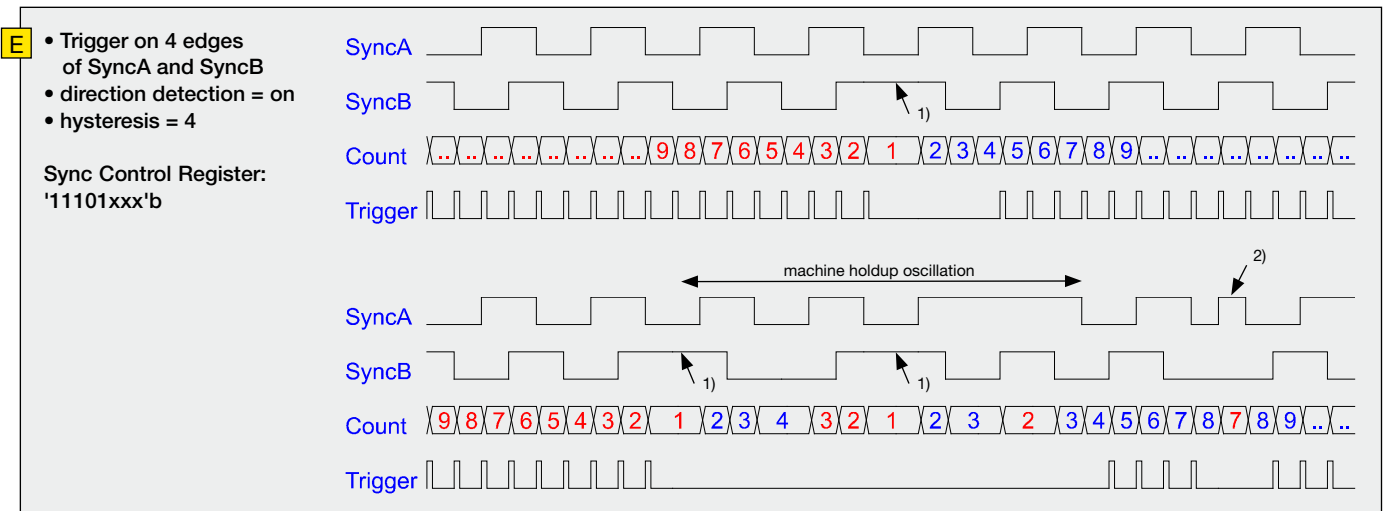
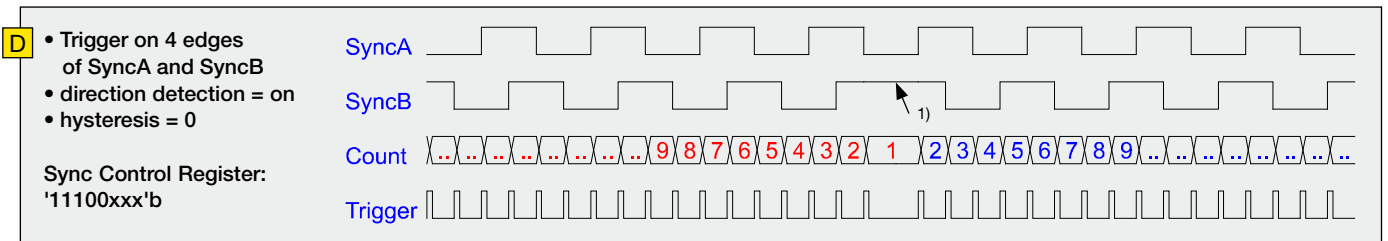
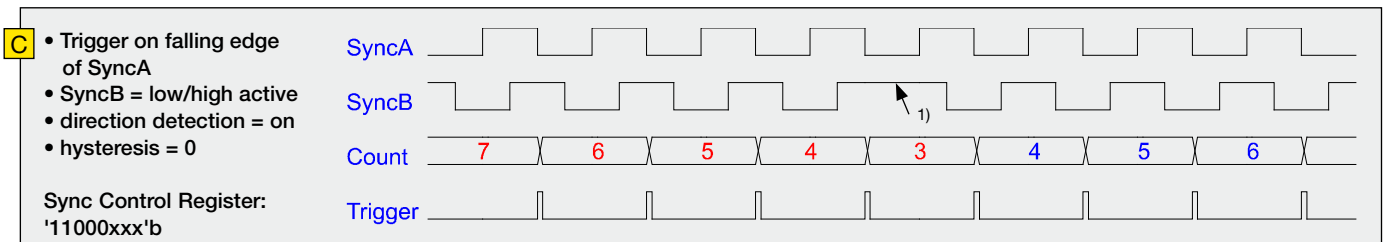
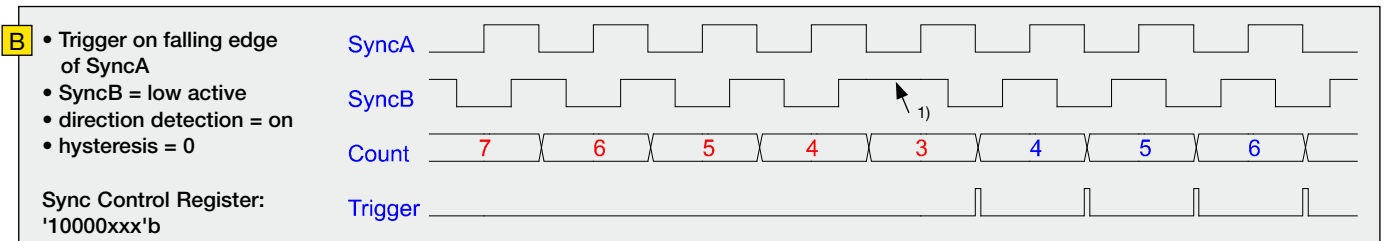
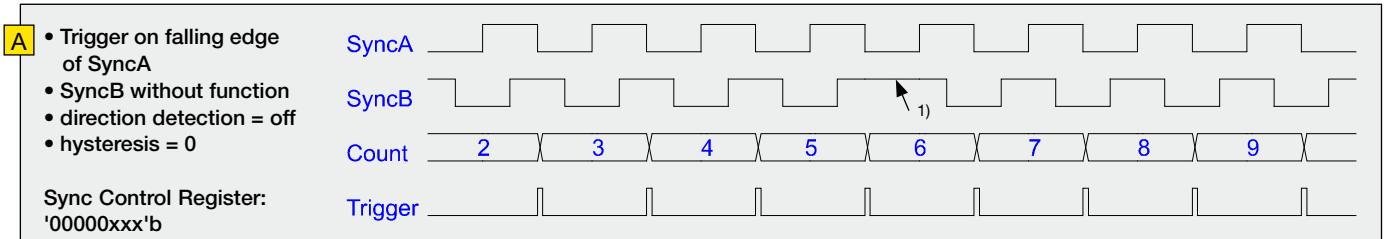

5 Sensor Information

Manufacturer: TOSHIBA Corporation
 Type: TCD1711DG
 Data source: TOSHIBA CCD Linear Image Sensor CCD (Charge Coupled Device) TCD1711DG, 2004-01-30

Features

- Number of Image Sensing Elements: 7450 elements
- Image Sensing Element Size: 4.7 μm by 4.7 μm on 4.7 μm center
- Photo Sensing Region: High sensitive and low voltage dark signal pn photodiode
- Clock: 2-phase (5 V)
- Package: 22-pin CERDIP package

Circuit Diagram and Pin Names

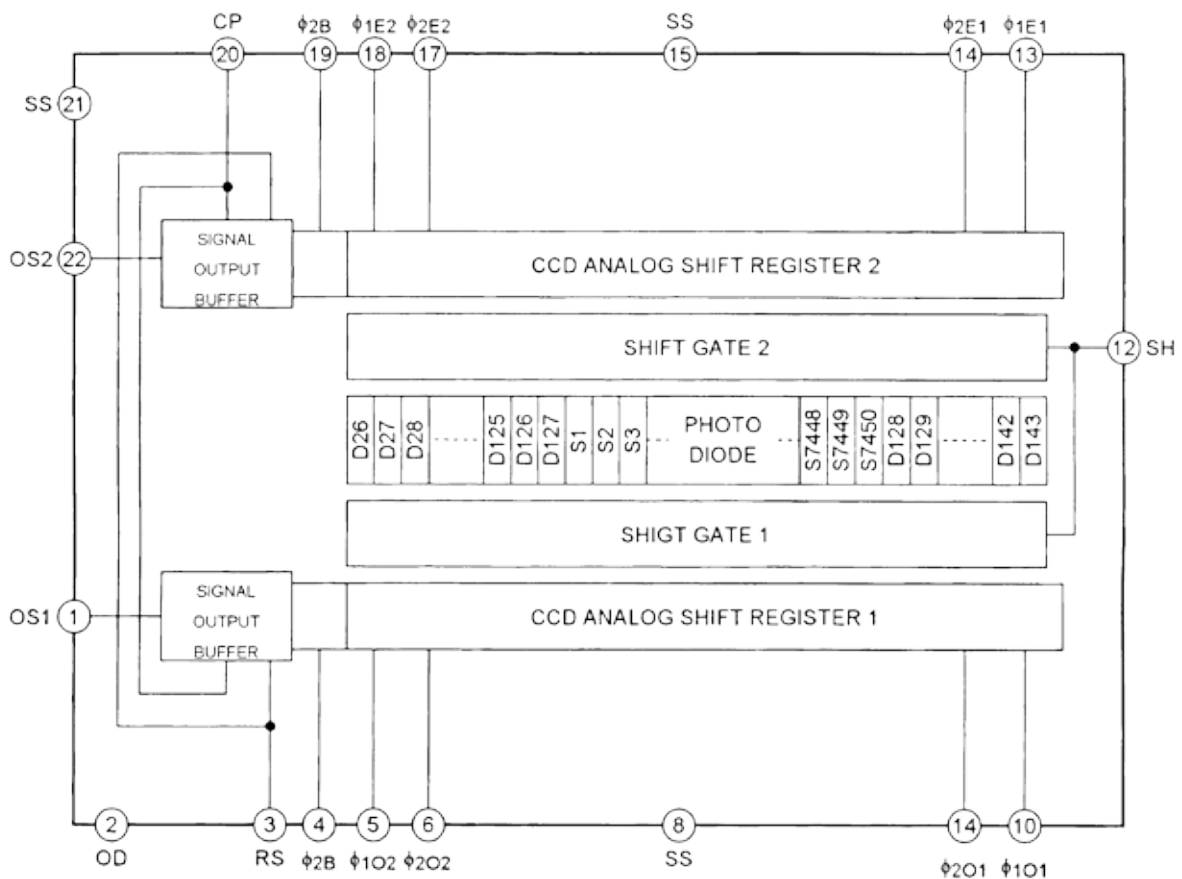

φ1E, O	Clock (Phase 1)
φ2E, O	Clock (Phase 2)
φ2B	Final Stage Clock (Phase 2)
SH	Shift Gate
RS	Reset Gate
CP	Clamp Gate
OS1	Signal Output 1
OS2	Signal Output 2
OD	Power
SS	Ground
NC	Non Connection

Line Scan Camera SK7456U3TO Manual (11.2015) • shared_sensor_TCD1711DG.indd (11.2015)

Optical/Electrical Characteristics

($T_a = 25^\circ\text{C}$, $V_{OD} = 10\text{ V}$, $V_\phi = V_{SH} = V_{RS} = V_{CP} = 5\text{ V}$ (ノイズ), $f_\phi = 1\text{ MHz}$,
 t_{INT} (INTEGRATION TIME) = 10 ms, LIGHT SOURCE = DAYLIGHT FLUORESCENT LAMP,
 LOAD RESISTANCE-100k Ω)

CHARACTERISTIC	SYMBOL	MIN	TYP	MAX	UNIT	NOTE
Sensitivity	R	12	15	18	V/lx·s	
Photo Response Non Uniformity	PRNU	—	4	10	%	(Note2)
	PRNU (3)	—	6	12	mV	(Note8)
Saturation Output Voltage	V_{SAT}	1.5	1.8	—	V	(Note3)
Saturation Exposure	SE	0.08	0.12	—	lx·s	(Note4)
Dark Signal Voltage	V_{DRK}	—	1.0	3	mV	(Note5)
Dark Signal Non Uniformity	DSNU	—	4.0	10	mV	(Note5)
DC Power Dissipation	P_D	—	250	375	mW	
Total Transfer Efficiency	TTE	92	98	—	%	
Output Impedance	Z_O	—	0.2	1	k Ω	
Dynamic Range	DR	—	1800	—		(Note6)
DC Signal Output Voltage	V_{OS1}	3.0	4.5	6.0	V	(Note7)
	V_{OS2}	3.0	4.5	6.0		
DC Differential Error Voltage	$ V_{OS1} - V_{OS2} $	—	—	300	mV	
Random Noise	N_{Ds}	—	1.0	—	mV	(Note9)

Note 2: Measured at 50% of SE (Typ.)

$$\text{Definition of PRNU : } PRNU = \frac{\Delta\bar{x}}{\bar{x}} \times 100(\%)$$

Where \bar{x} is average of total signal outputs and $\Delta\bar{x}$ is maximum deviation from \bar{x} under uniform illumination.
 (Channel 1)

In the case of 3725 elements (Channel 2), the condition is the same as above too.

Note 3: V_{SAT} is defined as minimum saturation output voltage of all effective pixels.

Note 4: Definition of SE : $SE = \frac{V_{SAT}}{R}$ (lx·s)

Note 5: V_{DRK} is defined as average dark signal voltage of all effective pixels.

DSNU is defined as different voltage between V_{DRK} and V_{MDK} when V_{MDK} is maximum dark signal voltage.

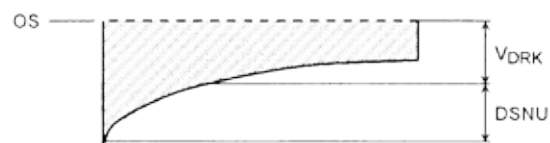

Note 6: Definition of DR : $DR = \frac{V_{SAT}}{V_{DRK}}$

V_{DRK} is proportional to t_{INT} (Integration Time).

So the shorter t_{INT} condition makes wider DR values.

Note 7: DC signal output voltage and DC compensation output voltage are defined as follows:

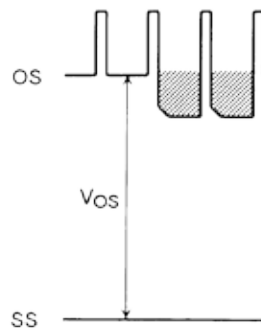

Note 8: PRNU (3) is defined as maximum voltage with next pixel, where measured 5% of SE (Typ.)

Note 9: Random noise is defined as the standard deviation (sigma) of the output level difference between two adjacent effective pixels under no illumination (i.e. dark condition) calculated by the following procedure.

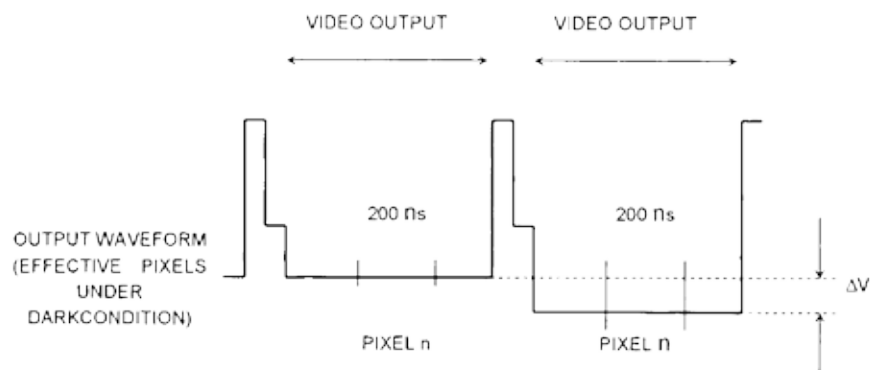

- 1) Two adjacent pixels (pixel n and n + 1) in one reading are fixed as measurement points.
- 2) Each of the output levels at video output periods averaged over 200 nanosecond period to get V_n and V_{n + 1}.
- 3) V_{n + 1} is subtracted from V_n to get ΔV.

$$\Delta V = V_n - V_{n + 1}$$
- 4) The standard deviation of ΔV is calculated after procedure 2) and 3) are repeated 30 times (30 readings).

$$\overline{\Delta V} = \frac{1}{30} \sum_{i=1}^{30} |\Delta V_i| \quad \sigma = \sqrt{\frac{1}{30} \sum_{i=1}^{30} (\Delta V_i - \overline{\Delta V})^2}$$

- 5) Procedure 2), 3) and 4) are repeated 10 times to get 10 sigma values.

$$\bar{\sigma} = \frac{1}{10} \sum_{j=1}^{10} \sigma_j$$

- 6) $\bar{\sigma}$ value calculated using the above procedure is observed $\sqrt{2}$ times larger than that measured relative to the ground level. So we specify the random noise as follows.

$$\text{Random noise} = \frac{1}{\sqrt{2}} \bar{\sigma}$$

Glossary

Exposure period

is the illumination cycle of a line scan sensor. It is the → *integration time* plus the additional time to complete the read-out of the accumulated charges and the output procedure. While the charges from a finished line scan are being read out, the next line scan is being exposed. The exposure period is a function of the pixel number and the → *pixel frequency*. The minimum exposure period of a particular line scan camera determines the maximum → *line frequency* that is declared in the specifications.

Integration control

Cameras with integration control are capable of curtailing the → *integration time* within an → *exposure period*. This performs an action equivalent to a shutter mechanism.

Integration time

The light-sensitive elements of the photoelectric sensor accumulate the charge that is generated by the incident light. The duration of this charge accumulation is called the integration time. Longer integration times increase the intensity of the line scan signal, assuming constant illumination conditions. The complete read-out of accumulated charges and output procedure determines the minimum → *exposure period*.

Line frequency, line scan frequency

is the reciprocal value of the → exposure period. The maximum line frequency is a key criterion for line scan sensors.

Optical resolution

Two elements of a line scan camera determine the optical resolution of the system: first, the pixel configuration of the line sensor and, secondly, the optical resolution of the lens. The worst value is the determining value. In a phased set-up, both are within the same range.

The optical resolution of the line sensor is primarily determined by the number of pixels and secondarily by their size and spacing, the inter-pixel distance. Currently available line scan cameras have up to 12000 pixels, ranging from 4 to 14 µm in size and spacing, for sensors up to 56 mm in length and line scan frequencies up to 83 kHz.

During a scanning run, the effective resolution perpendicular to the sensor orientation is determined by the velocity of the scan and by the → *line frequency*

Pixel frequency

The pixel frequency for an individual sensor is the rate of charge transfer from pixel to pixel and its ultimate conversion into a signal.

Shading correction

→ *Shading Correction*, section 3.2

SCM

Shading Correction Memory,

→ *Shading Correction Memories and API Functions*, section 3.2

SOS

Start of scan,

→ *Advanced Synchronization Control*, section 4.2

SkLineScan

is the software application by Schäfter + Kirchhoff to control and to adjust the line scan cameras,

→ *Software: SkLineScan*, section 3.1

Synchronization

To obtain a proportional image with the correct aspect ratio, a line synchronous transport with the laterally correct pixel assignment is required. The → *Line frequency* and a constant object velocity have to be compatible with each other.

For more accurate requirements or with a variable object velocity then external synchronization is necessary.

→ *Synchronization of the Imaging Procedure and the Object Scan Velocity*, section 3.2

CE-Conformity

The product complies with the following standards and directives:

2004/108/EG

EMC Directive

DIN EN 61326-1:2013

Electrical equipment for measurement, control and laboratory use – EMC requirements

Part 1: General requirements

Part 2-3: Particular requirements – Test configuration, operational conditions and performance criteria for transducers with integrated or remote signal conditioning

Warranty

This manual has been prepared and reviewed as carefully as possible but no warranty is given or implied for any errors of fact or in interpretation that may arise. If an error is suspected then the reader is kindly requested to inform us for appropriate action.

The circuits, descriptions and tables may be subject to and are not meant to infringe upon the rights of a third party and are provided for informational purposes only.

The technical descriptions are general in nature and apply only to an assembly group. A particular feature set, as well as its suitability for a particular purpose, is not guaranteed.

Each product is subjected to a quality control process. If a failure should occur then please contact the supplier or Schäfter+Kirchhoff GmbH immediately. The warranty period covers the 24 months from the delivery date. After the warranty has expired, the manufacturer guarantees an additional 6 months warranty for all repaired or substituted product components. Warranty does not apply to any damage resulting from misuse, inappropriate modification or neglect. The warranty also expires if the product is opened. The manufacturer is not liable for consequential damage. If a failure occurs during the warranty period then the product will be replaced, calibrated or repaired without further charge. Freight costs must be paid by the sender. The manufacturer reserves the right to exchange components of the product instead of making a repair. If the failure results from misuse or neglect then the user must pay for the repair. A cost estimate can be provided beforehand.

Copyright ©

Unless explicitly allowed, the duplication, distribution, sale or use of this document or its contents, for purposes other than those intended, is forbidden. Repeated transgressions will lead to prosecution and demands for compensation.

All rights of patent protection and registration or copyright of a product or its design lie with Schäfter+Kirchhoff. Schäfter+Kirchhoff GmbH and the Schäfter+Kirchhoff logo are registered trademarks.

We reserve the right to improve or change specifications so that the system description and depictions in the Instruction Manual may differ in detail from the system actually supplied. The Instruction Manual is not covered by an update service.

Date of document publication: 10.11.2015

Schäfter+Kirchhoff GmbH
Kieler Straße 212
22525 Hamburg
Germany

Tel.: +49 40 853 997-0
Fax: +49 40 853 997-10
Email: info@SuKHamburg.de
Internet: www.SuKHamburg.com

Accessories and Spare Parts

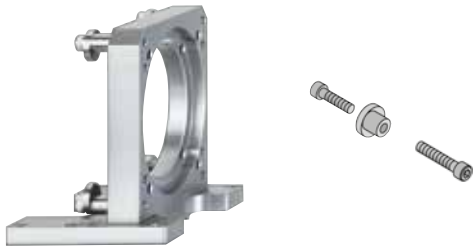

Mounting bracket

SK5105

Order Code

Warp-resistant construction for mounting the line scan camera

Clamp set

SK5102

Order Code

to lock the line scan camera in a desired position (set of 4)



Mounting console

SK5105-2

Order Code

for indirect mounting of the line scan camera via the extension tube, suitable for an extension tube larger than 50 mm, for example with a macro lens.



USB 3.0 cable SK9020.3

Camera connector: USB 3.0 plug, type micro-B, with safety lock screws

PC connector: USB 3.0 plug, type A (also fits into a USB 2.0 type A socket)

SK9020.3

Order Code

3 = 3 m cable length (standard)

5 = 5 m cable length



External synchronization cable SK9026...

applicable when no power supply in addition to the USB interface is required. Shielded cable with Hirose plug HR10A, female 6 pin, (camera side) and Phoenix 4 pin connector incl. terminal block.

SK9026.x

Order Code

3 = 3 m cable length

5 = 5 m cable length



Lenses:

- high resolution **enlarging and macro lenses**
- high speed **photo lenses**
- lenses with additional **blocking bridge** for locking of focus and aperture setting

Adapter:

Lens adapter AOC-...

- for fitting photo lenses onto the CCD line scan camera

Focus adapter FA22-...

- for fitting enlarging or macro lenses



Software

SK91USB3-WIN

Order Code

SkLineScan operating program with oscilloscope display and scan function for setting camera parameters via USB

Operating systems:

Windows 7 (x64 and x86), Windows XP (SP3)

SK91USB3-LV

Order Code

VI library for LabVIEW