

Fiber receptacle type FC-SMA

clamp screws for locking optics position (2x120°) using screw-driver size 1.2mm 9D-12

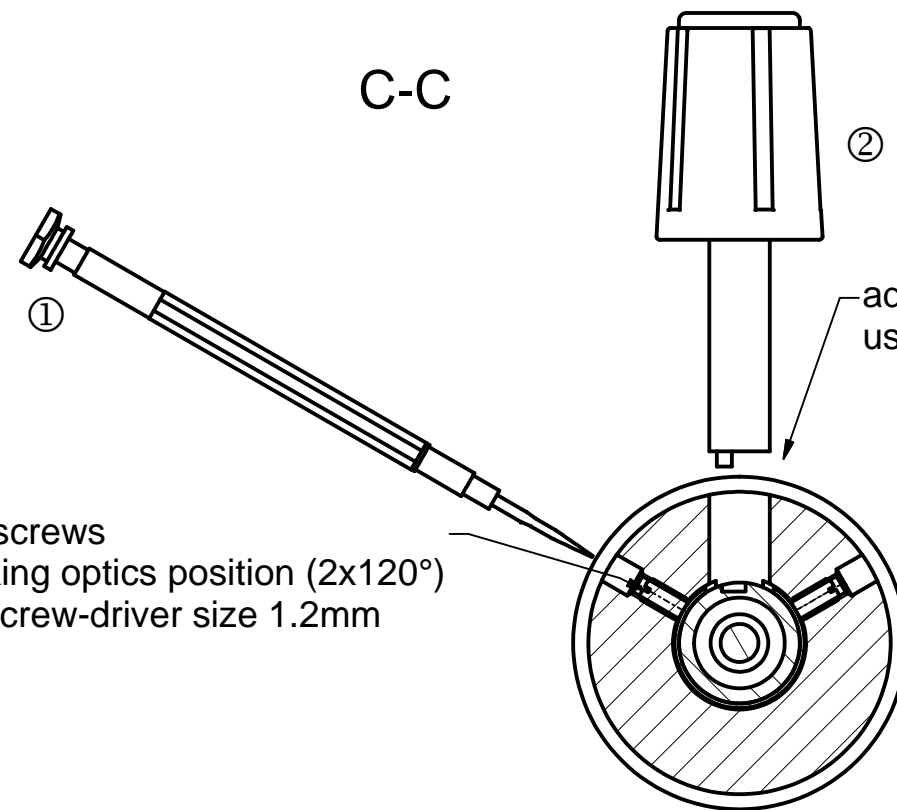

adjustment of focus setting using eccentric-key 60EX-4

adjustment of focus setting using eccentric-key 60EX-4 ②

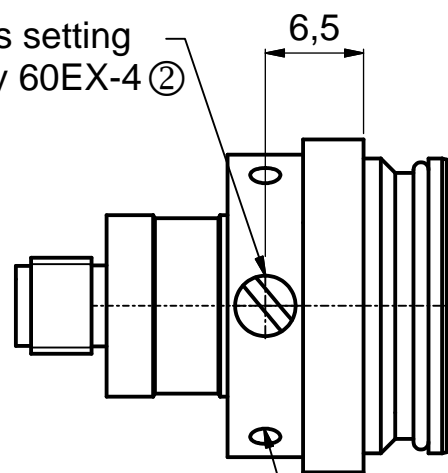

clamp screws for locking optics position (2x120°) using screw-driver size 1.2mm 9D-12 ①

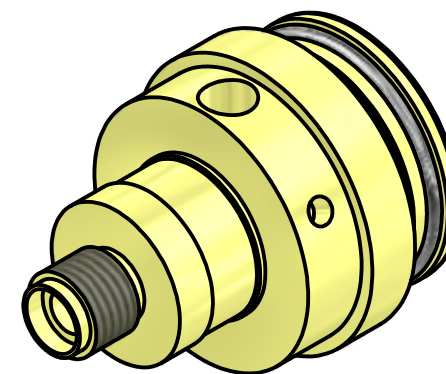

! Don't touch any other screws !

Tools for assembly and adjustment

screw driver size 1.2mm 9D-12

eccentric-key 60EX-4

①

②



		Allgemeintoleranz ISO 2768 - f		Maßstab:	
		Datum		Name	
		Bearb. 14.06.2016		A.Trapp	
		Gepr.			
		Norm			
		Schäfter&Kirchhoff		Blatt A3	
		OPTO-SENSORIK UND MESSTECHNIK		9709-2052-0552	
		OPTIK-ENTWICKLUNG/ELEKTRONIK/SENSORTECHNIK/SOFTWARE		Blatt: 2	
Zust.	Änderungen	Datum	Name	Datei: 970920520552.idw	Modell: 970920520552.iam