

! Pin screw for additional locking of the fiber ferrule:
- before pulling the connector:
unlock the pin screw.
-before inserting the connector:
make sure the ferrule is not blocked by the pin screw!
(using screw-driver size 1.2mm 9D-12 ①)

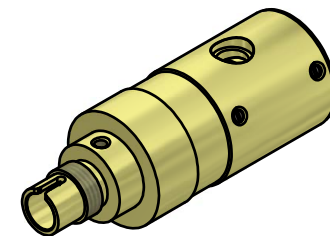
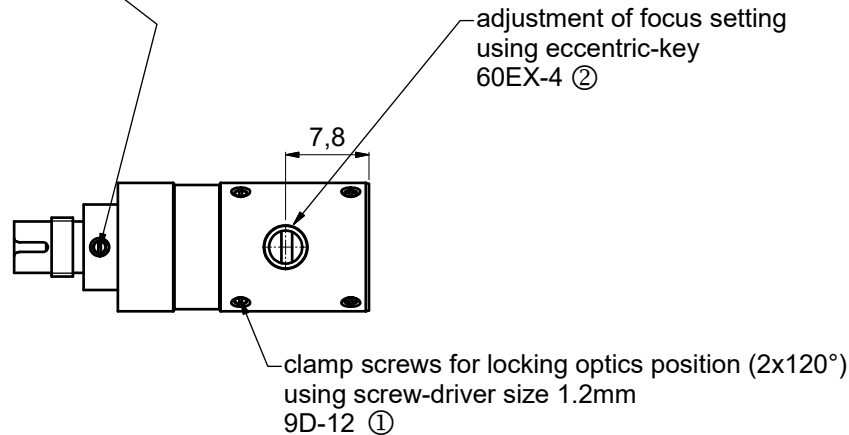

! Don't touch any other screws !

For information only
Not for manufacturing purposes

Tools for assembly and adjustment

screw driver size 1.2mm 9D-12
eccentric-key 60EX-4

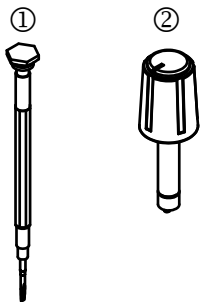

Dimensions DIN EN ISO 14405					Scale: 2:1	
				Date 18.02.2021	Name A. Trapp	60FC-LSA-0-XX-xx
				editor		Fiber collimator f' 1.5to 12 mm
				exam.		60FC-LSA-0-XX-xx
				free		Customer Drawing
				Schäfter+Kirchhoff OPTICS, METROLOGY, AND PHOTONICS		9709-2052-0616
				File: 970920520616.idw		Model: 970920520616.iam
						Size: A3 Page: 1