

Thrust and tension screw (3x120°)  
for tilt adjustment  
with hex key wrench size 1.5mm  
50HD-15 ①

Rotation of the quarter wave plate  
with adjustment key ④

Thrust screw M3 max.torque 50Ncm

Tension screw M2 max.torque 40Ncm

hex-key size 1.5mm 50HD-15    screwdriver size 1.2mm 9D-12    eccentric-key 55EX-5    Adjustment key 60Z-2303

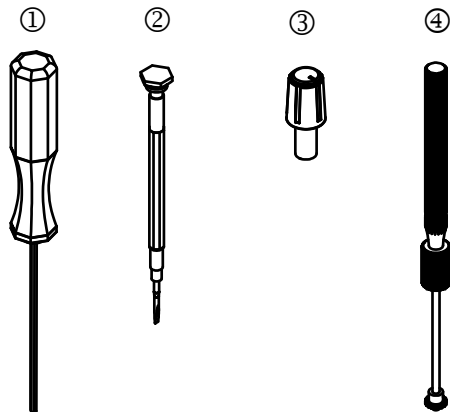

! Pin screw for additional locking of the fiber ferrule:  
- before pulling the FC-connector:  
unlock the pin screw.  
- before inserting the FC-connector:  
make sure the ferrule receptacle is not blocked  
by the pin screw !

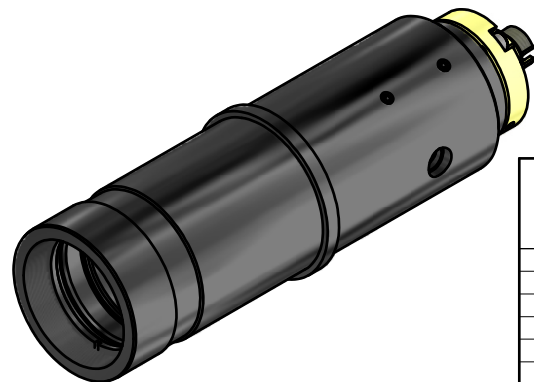
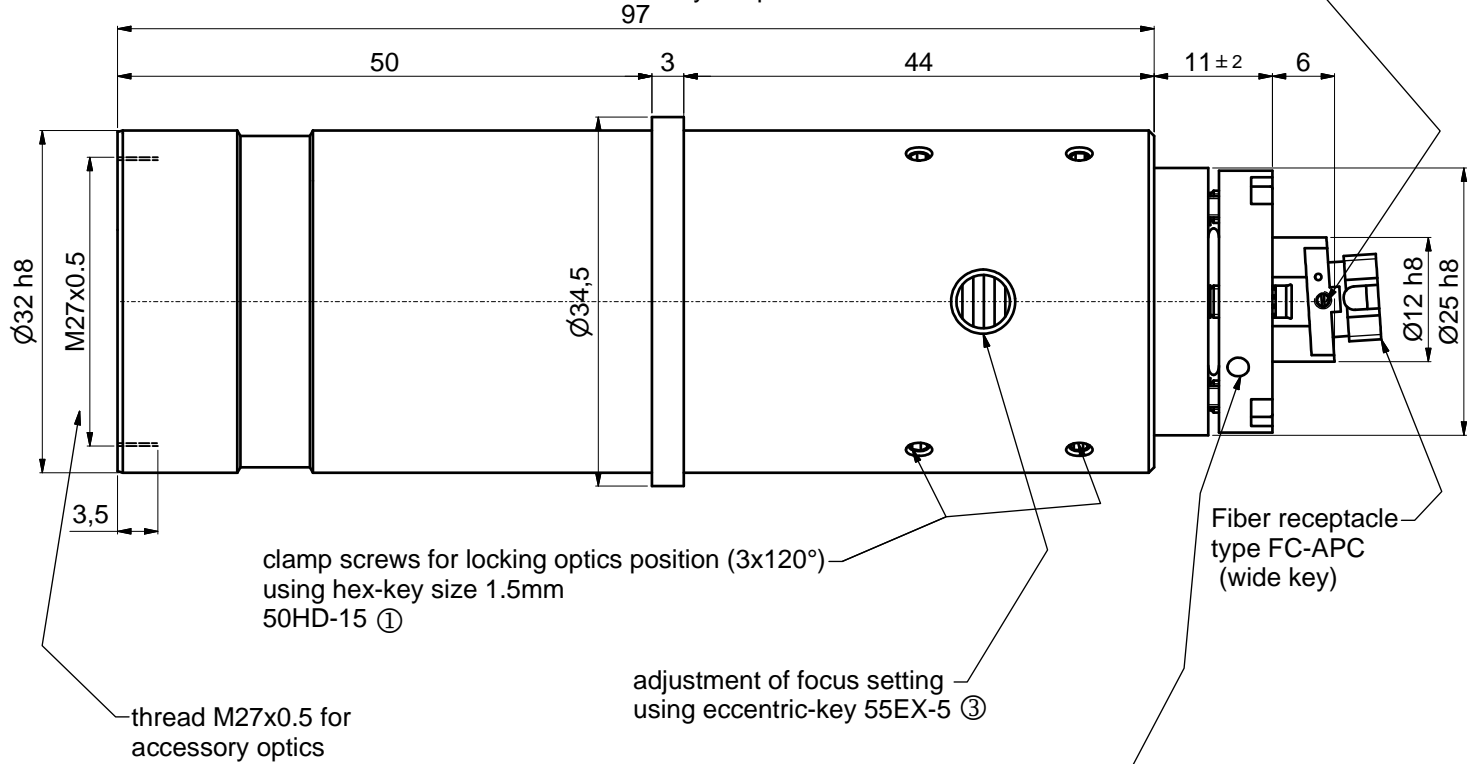

Allgemeintoleranz ISO 2768 - f		Maßstab: 2:1	
60FC-Q-4-M100S-xx		Fiber collimator f'100mm	
Fiber receptacle type FC-APC		9802-4186-5400	
Schäfter&Kirchhoff OPTO-SENSORIK UND MESSTECHNIK OPTIK-ENTWICKLUNG/ELEKTRONIK/SORTIMENT/SOFTWARE		Blatt A3	
Zust.		Blatt 2	
Änderungen		Datum	
Name		Datei: 980241865400.idw	
Datum		Modell: 980241865400.iam	