

Clamping screw for locking of lens attachments (3x120°) screws not included

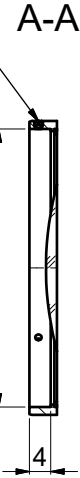

Thrust and tension screw (3x120°) for tilt adjustment with hex key wrench size 1.5mm 50HD-15 ①

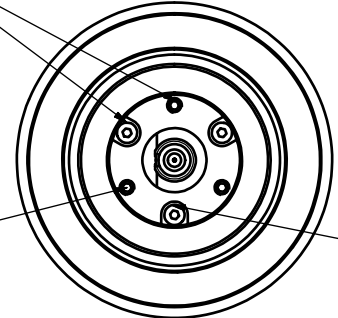

Thrust screw M3 max.torque 50Ncm

Tension screw M2 max.torque 40Ncm

! Pin screw for additional locking of the fiber ferrule:
 - before pulling the FC-connector: unlock the pin screw.
 - before inserting the FC-connector: make sure the ferrule receptacle is not blocked by the pin screw !

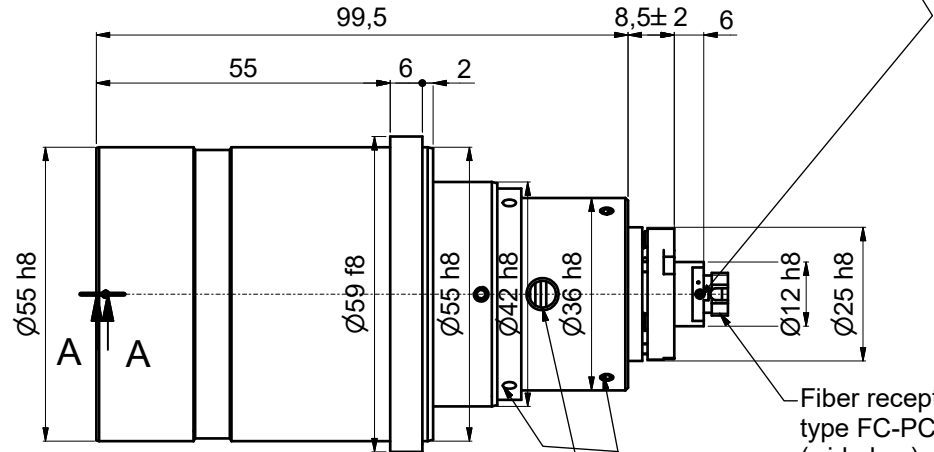

Fiber receptacle type FC-PC (wide key)

Stop screw (2x/3x120°) for locking optics position using hex key 1.5mm 50HD-15 ①

adjustment of focus setting using eccentric-key 55EX-5 ③

For information only
 Not for manufacturing purposes

! Don't touch any other screws !

Tools for assembly and adjustment

hex-key size 1.5mm 50HD-15	screw driver size 1.2mm 9D-12	eccentric-key 55EX-5
----------------------------	-------------------------------	----------------------

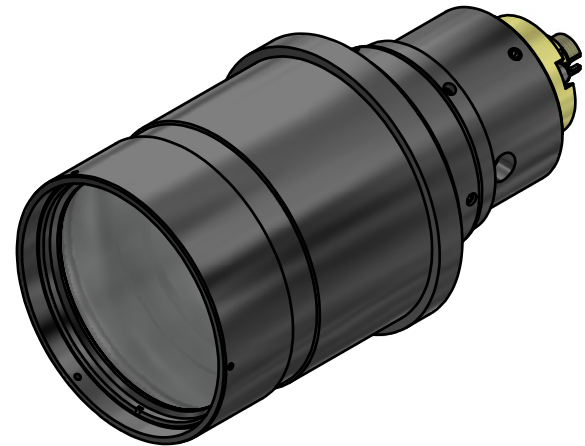

Allgemeintoleranz ISO 2768 - f		Maßstab: 2:1	
Datum		Name	
Bearb.	18.05.2016	A.Trapp	
Gepr.			
Norm			
Schäfter&Kirchhoff		60FC-T-0-M100-xx	
OPTO-SENSORIK UND MESSTECHNIK		60FC-T-0-M100-xx	
OPTIK-ENTWICKLUNG/ELEKTRONIK/SORTECHNIK/SOFTWARE		Fiber receptacle type FC-PC	
		9802-4150-0032	
		Blatt A3	
		Blatt 1	
Zust.	Änderungen	Datum	Name
Datei: 980241500032.idw		Modell: 980241500032.iam	