

Thrust and tension screw (3x120°)
for tilt adjustment
with hex key wrench size 1.5mm
50HD-15 ①

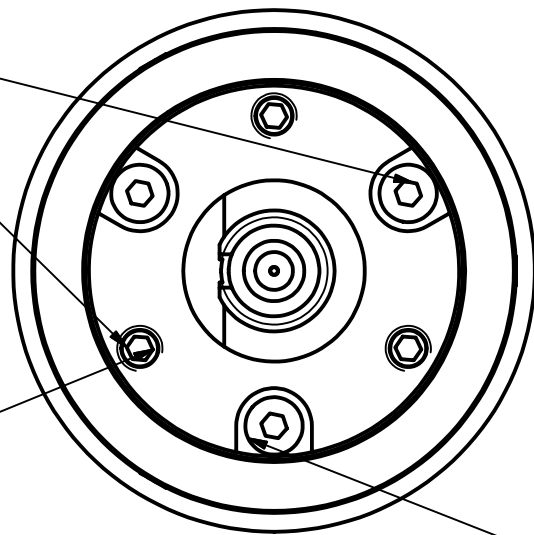

Thrust screw M3 max.torque 50Ncm

Tension screw M2 max.torque 40Ncm

! Pin screw for additional locking of the fiber ferrule:
- before pulling the FC-connector:
unlock the pin screw.
- before inserting the FC-connector:
make sure the ferrule receptacle is not blocked
by the pin screw !

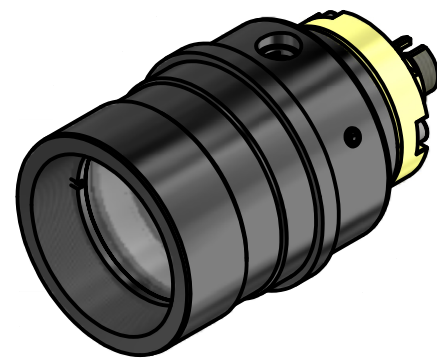
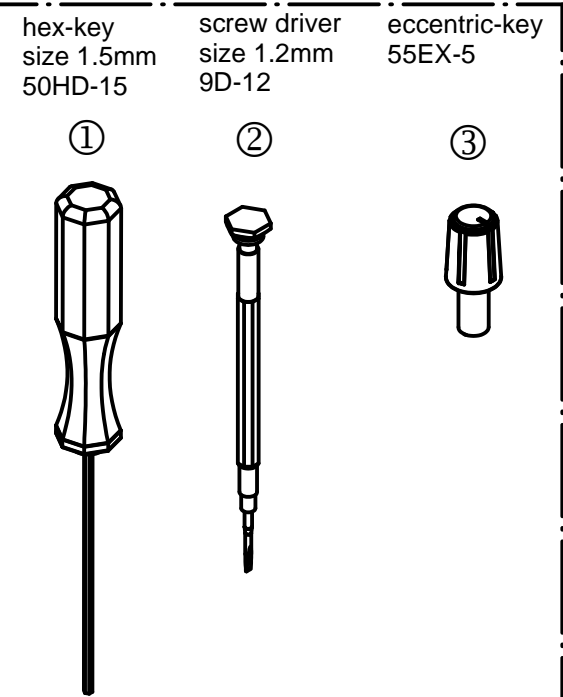
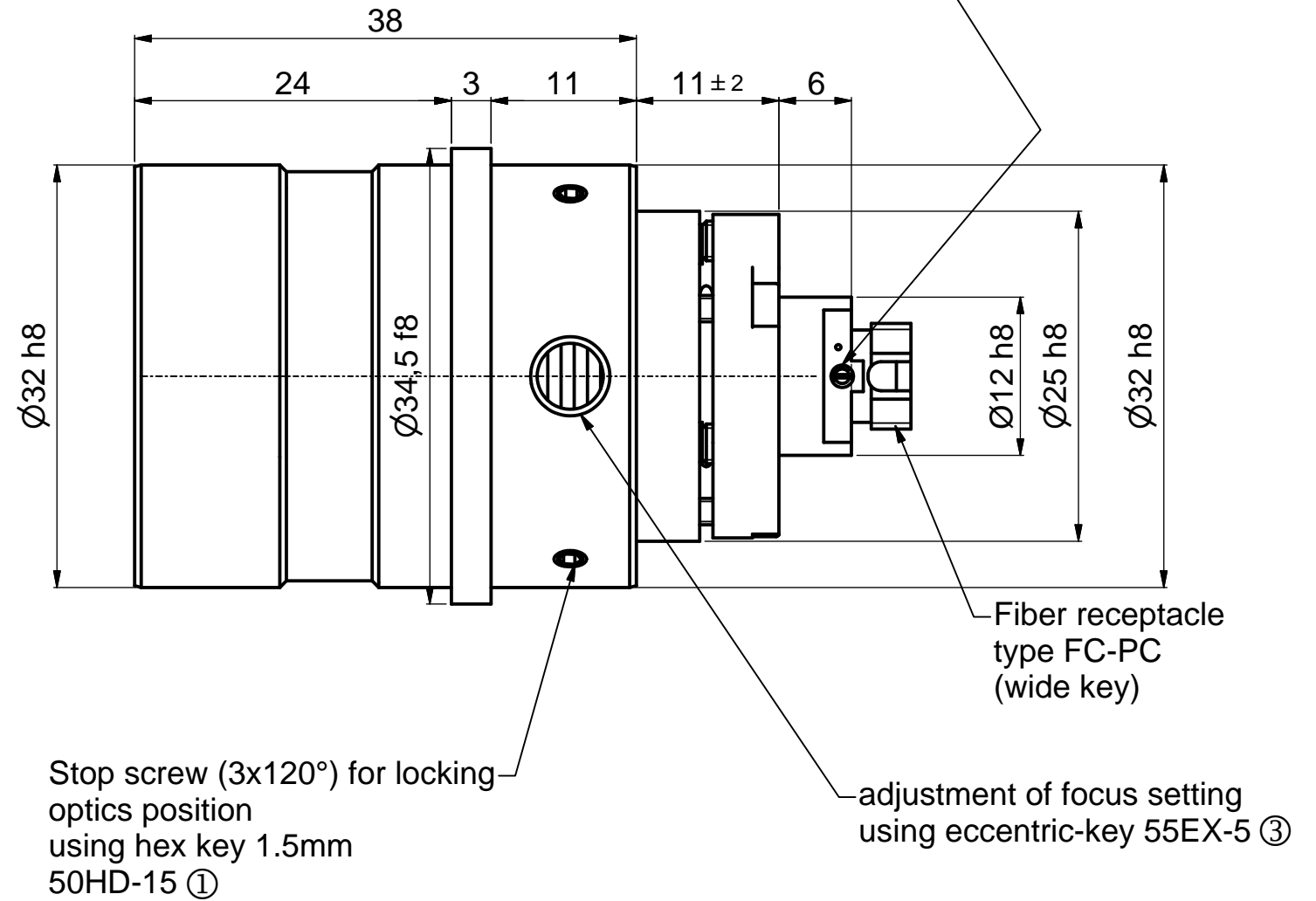

! Don't touch any other screws !

		Allgemeintoleranz ISO 2768 - f		Maßstab: 2:1	
		Datum		Name	
		21.03.2017		Tp	
		Gepr.			
		Norm			
				60FC-T-0-M40L-xx	
				Fiber collimator f'40	
				Fiber receptacle type FC-PC	
				9802-4186-5500	
				Blatt A3	
				Blatt: 2	
Zust.	Änderungen	Datum	Name	Datei: 980241865500.idw	Modell: 980241865500.iam