

Thrust and tension screw (3x120°)
for tilt adjustment
with hex key wrench size 1.5mm
50HD-15 ①

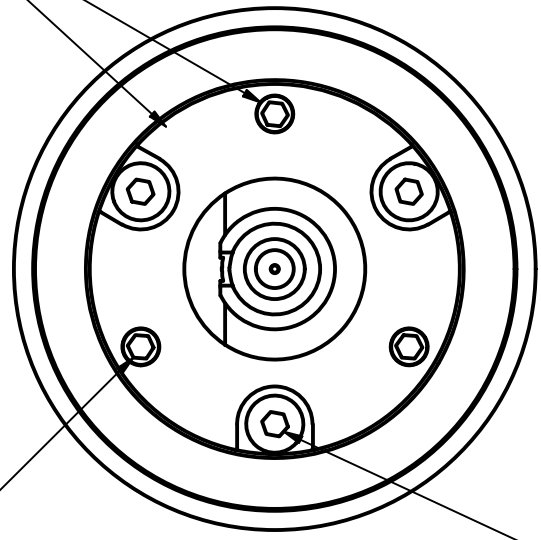

Thrust screw M3 max.torque 50Ncm
Tension screw M2 max.torque 40Ncm

clamp screws for locking optics position (3x120°)
using hex-key size 1.5mm
50HD-15 ①

! Pin screw for additional locking of the fiber ferrule:
- before pulling the FC-connector:
unlock the pin screw.
- before inserting the FC-connector:
make sure the ferrule receptacle is not blocked
by the pin screw ! ②

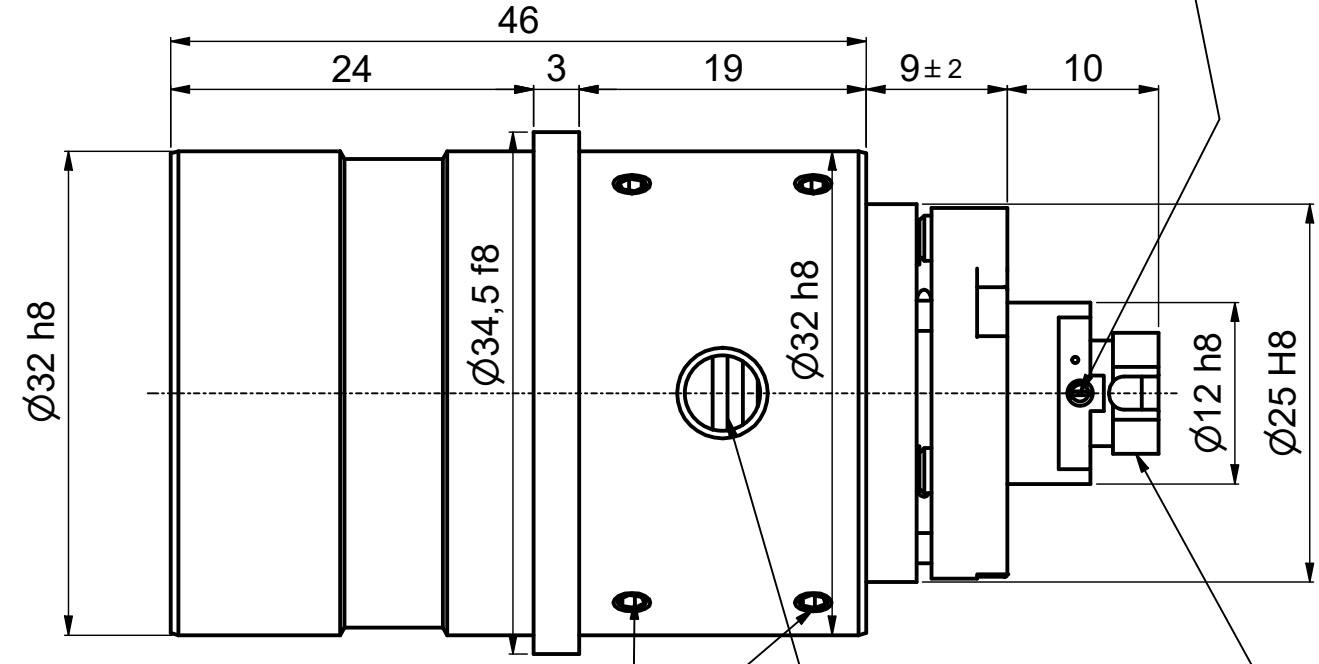

adjustment of focus setting
using eccentric-key 55EX-5 ③

Fiber receptacle
type FC-PC

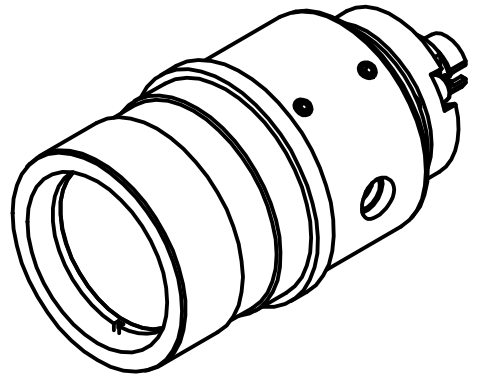
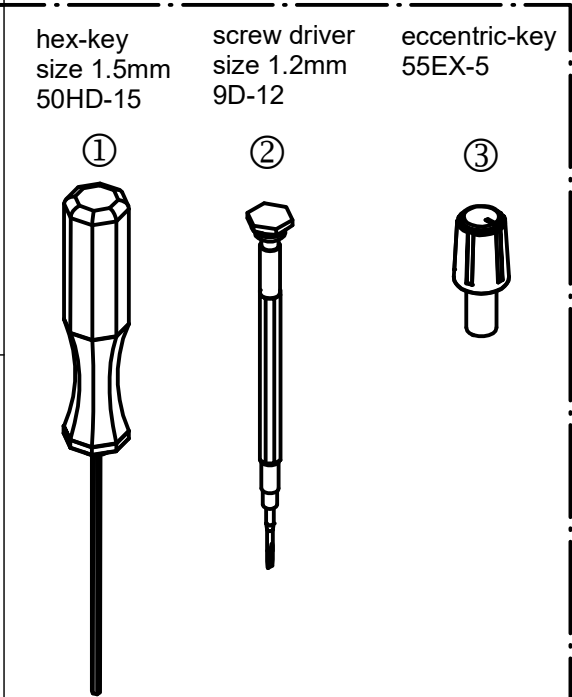

! Don't touch any other screws !

Dimensions DIN EN ISO 14405	Scale: 3:1		60FC-T-0-M50L-37s
	Faserkollimator f'50/NA0.24 mit FC-PC Anschluß		
Date		Name	
editor 24.06.2019		Boyn	
exam.			
free			
Schäfter+Kirchhoff OPTICS, METROLOGY, AND PHOTONICS			9802-4188-5950
File: 980241885950.idw			Model: 980241885950.iam
			Size: A3 Page: 2