

Thrust and tension screw (3x120°)  
for tilt adjustment  
with hex key wrench size 1.5mm  
50HD-15 ①

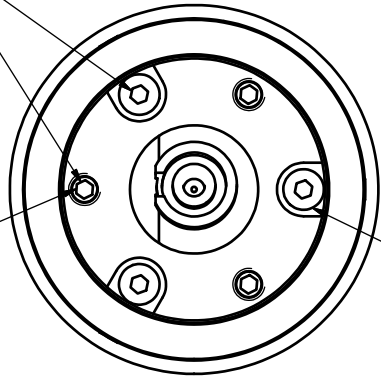

Thrust screw M3 max.torque 50Ncm

Tension screw M2 max.torque 40Ncm

! Pin screw for additional locking of the fiber ferrule:  
- before pulling the FC-connector:  
unlock the pin screw.  
- before inserting the FC-connector:  
make sure the ferrule receptacle is not blocked  
by the pin screw !

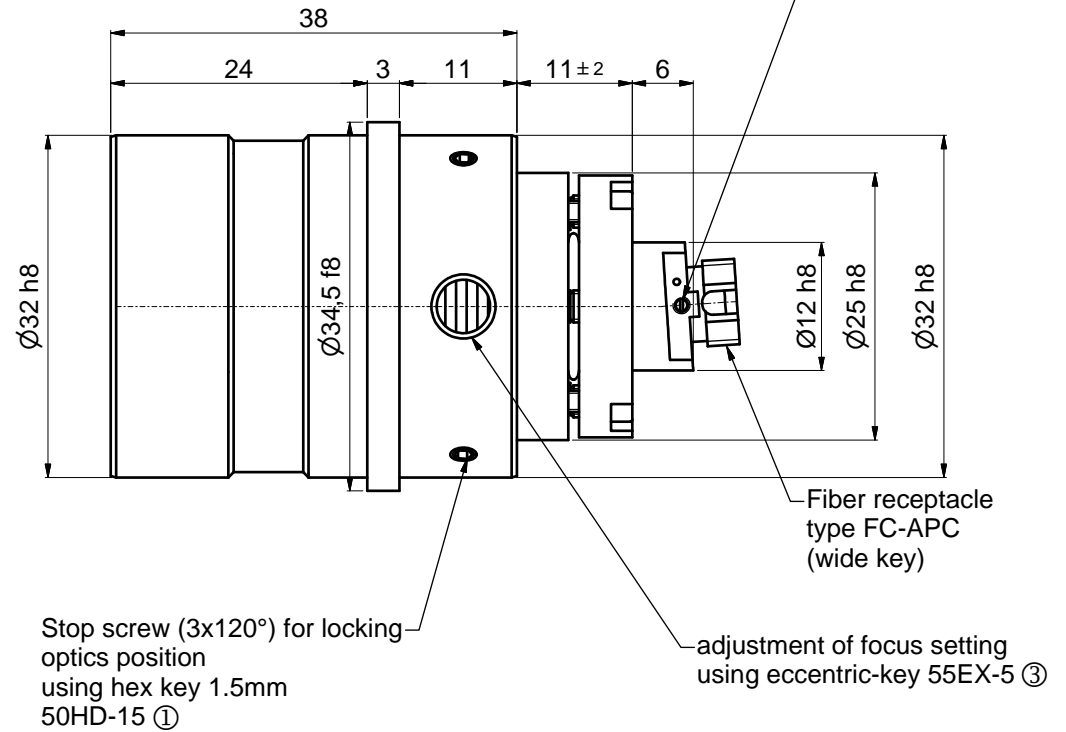

! Don't touch any other screws !

hex-key  
size 1.5mm  
50HD-15

screw driver  
size 1.2mm  
9D-12

eccentric-key  
55EX-5

①

②

③

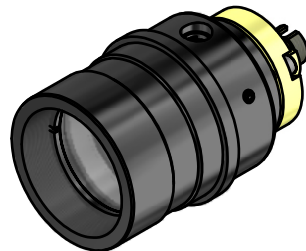

Allgemeintoleranz ISO 2768 - f		Maßstab: 2:1	
Bearb. 21.03.2017		60FC-T-4-M40L-xx	
Gepr.		Datum Name	
Norm		21.03.2017 Tp	
Schäfter&Kirchhoff		Fiber collimator f'40	
OPTO-SENSORIK UND MESSTECHNIK		Fiber receptacle type FC-APC	
OPTIK-ENTWICKLUNG/ELEKTRONIK/SORTIMENTE/SOFTWARE		9802-4186-3900	
Zust.		Blatt A3	
Änderungen		Blatt 2	
Datum		Datei: 980241863900.idw	
Name		Modell: 980241863900.iam	