

M2.5x0.45 - 6H

□22,06

120°

M4x0.7 - 6H

6

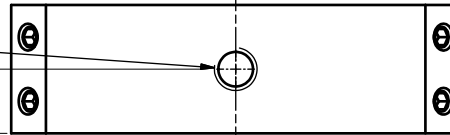

□42

□30/Ø6

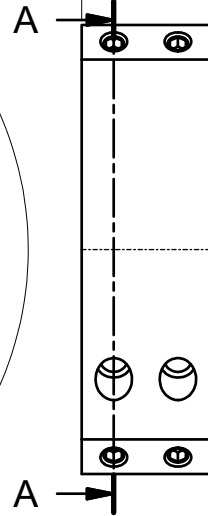

12

Ø25

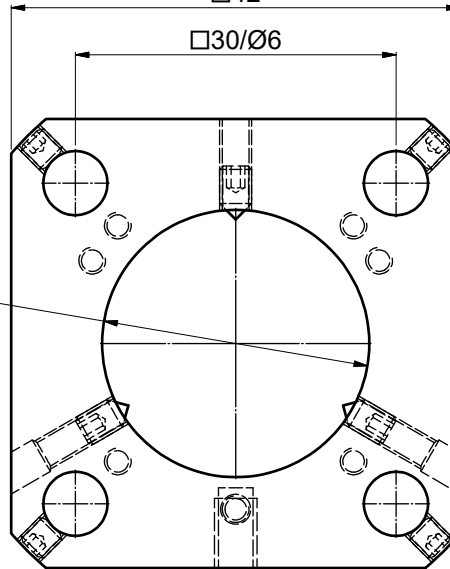

A-A

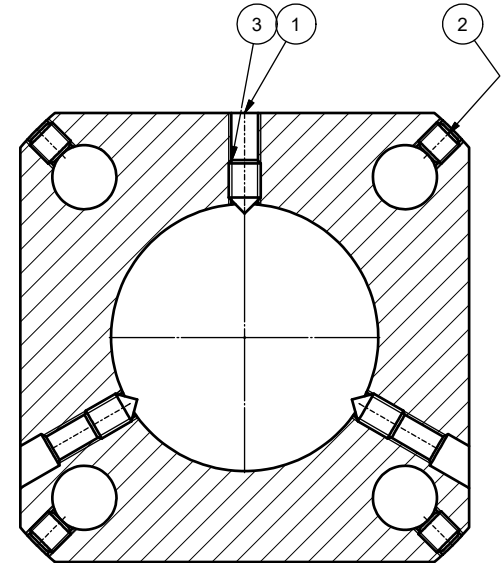

DIN 913 - M3 x 3

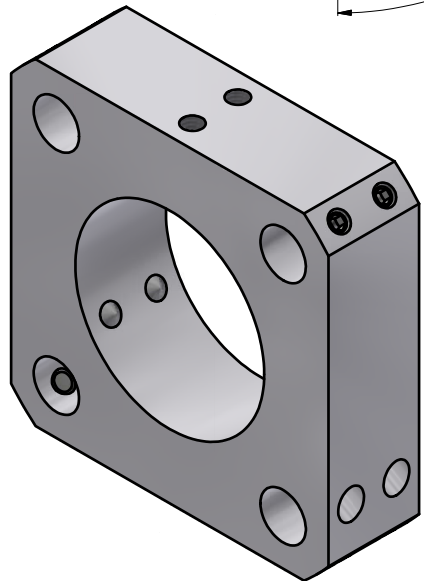
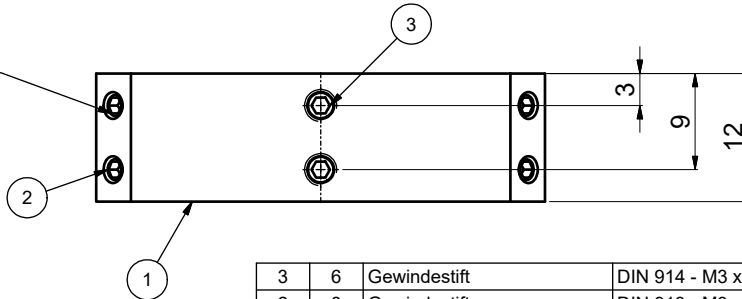

Pos.	Mge	Benennung	Sachnr./Bez.	Werkst.	Teil
3	6	Gewindestift	DIN 914 - M3 x 5	Stahl, weich, unlegiert	
2	8	Gewindestift	DIN 913 - M3 x 3	Stahl, weich, unlegiert	
1	1	MB-Konsole NW 25	9809-1030-2504	AlMg4,5Mn0,7	120147

Stückliste

Allgemeintoleranz ISO 2768 - f		Maßstab: 2:1	
Datum		Name	
Bearb.	01.10.2015	A. Trapp	
Gepr.			
Norm			
Schäfter&Kirchhoff		8909-1033-0201	
OPTO-SENSORIK UND MESSTECHNIK		Blatt A3	
01	M4 hinzu	23.05.2923	Tp
Zust.	Änderungen	Datum	Name
Datei: 980910330201.idw		Blatt 1	
Model: 980910330201.iam			

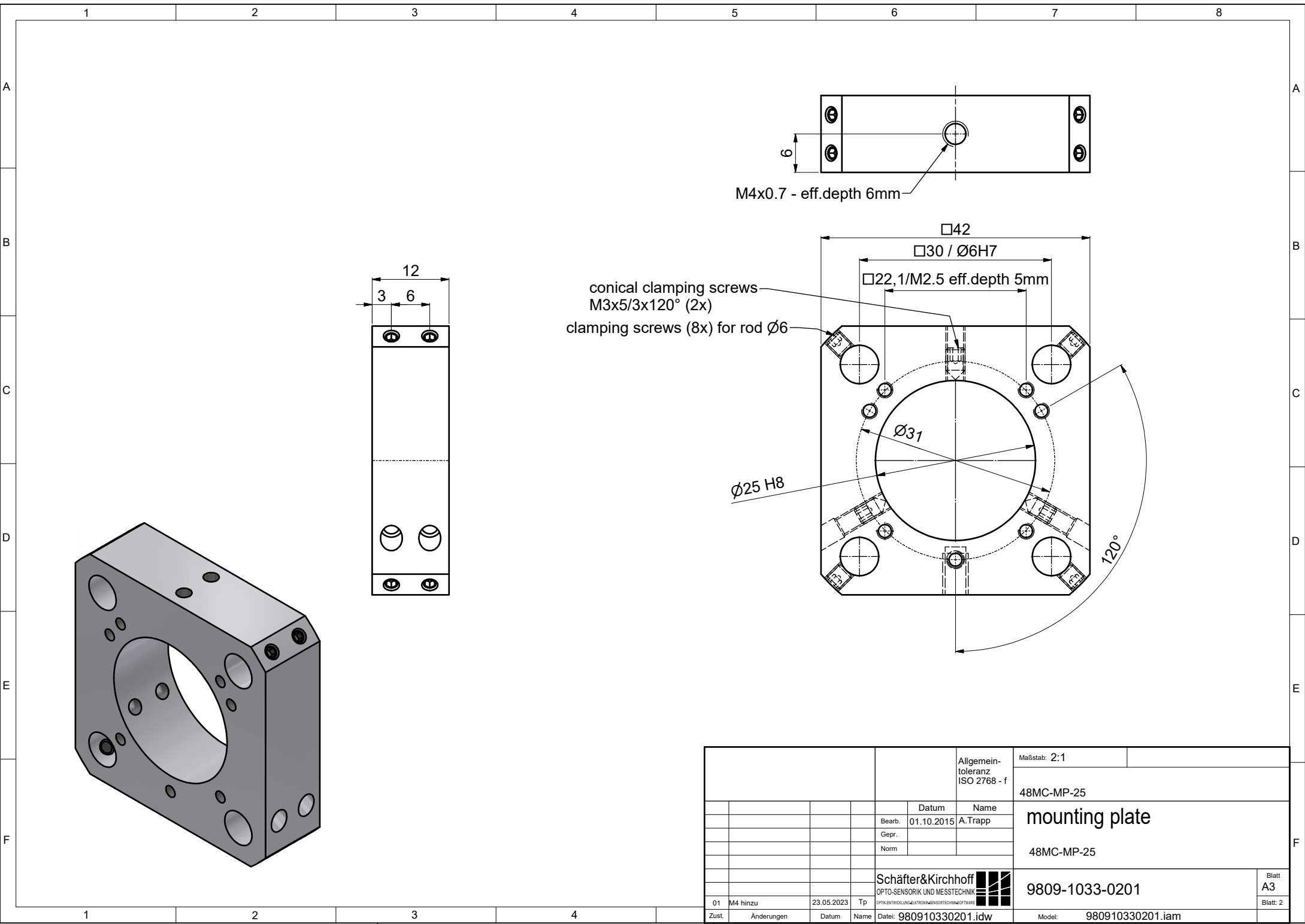

Allgemeintoleranz ISO 2768 - f		Maßstab: 2:1	
48MC-MP-25		mounting plate	
48MC-MP-25		9809-1033-0201	
Schäfter&Kirchhoff OPTO-SENSORIK UND MESSTECHNIK		Blatt A3	
Blatt A3		Blatt: 2	
01	M4 hinzu	23.05.2023	Tp
Zust.	Änderungen	Datum	Name
Datei: 980910330201.idw		Model: 980910330201.iam	